

FITTING INSTRUCTION

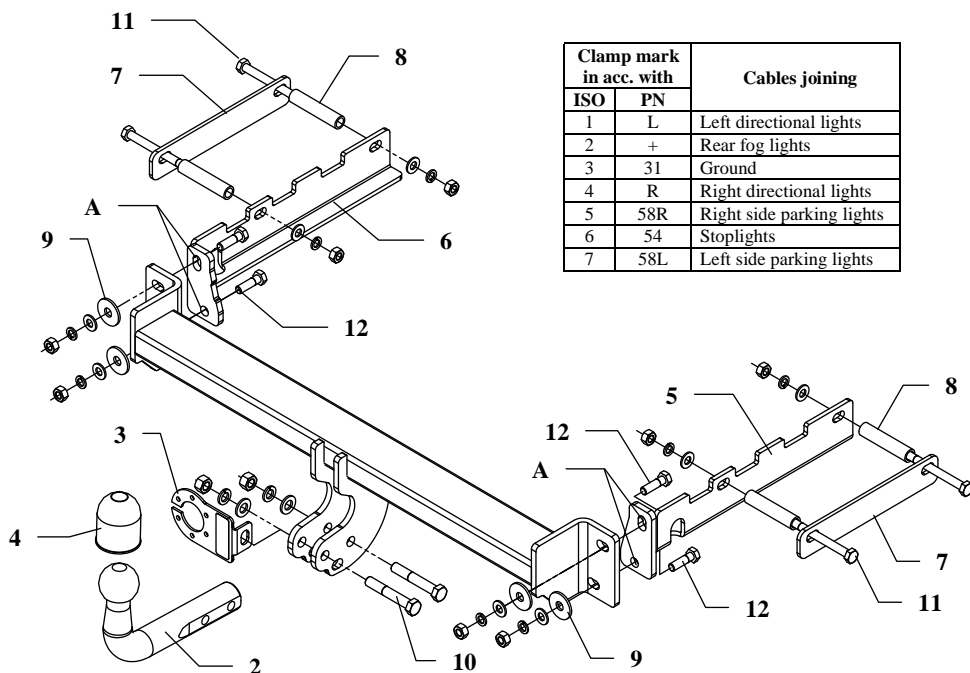

This towbar is designed to assembly in following car:
FORD MONDEO 4-5 doors, produced since 1993 till 08.1996, catalogue no. **C014** and is prepared to tow trailers max total weight **1800 kg** and max vertical load **75 kg**.

From manufacturer

Thank you for buying our product. Their reliability has been confirmed in many tests. Reliability of towbar depends also on correct assembly and correct exploitation. For this reasons we kindly ask to read carefully this instruction and apply to hints.

The towbar should be install in points described by a car producer.

The instruction of the assembly

1. Disassemble the bumper.
2. From below the car fix to chassis members brackets pos. 5 and 6 (from inside) by bolts M10x110mm (pos. 11), distance sleeves (pos. 8) and fish-plates (pos. 7) from accessories t.
3. Main bar of the towbar (pos. 1) put to rear panel and through existing holes and holes pos. A fix using bolts M10x35mm (pos. 12) together with mounted brackets.
4. In lower part of the bumper cut out suitable fragment and next install the bumper.
5. Tighten all bolts according to the torque shown in the table.
6. Fix tow-ball (pos. 2) and socket plate (pos. 3) using bolts M12x75mm (pos. 10) from accessories.
7. Connect electric wires of 7-poles socket according to the instruction of the car. (Recommend to make at authorized service station)
8. Complete paint layer damaged during installation.

Torque settings for nuts and bolts (8,8):

M6 - 11 Nm	M8 - 25 Nm	M10 - 50 Nm
M12 - 87 Nm	M14 - 138 Nm	M16 - 210 Nm











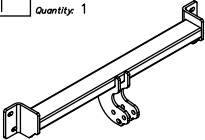

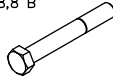

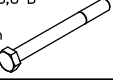

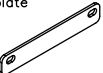
NOTE

After install the towbar you should get adequate note in registration book (at authorised service station).The car should be equipped with:

- Indicators
- Tow mirrors

After **1000km** of exploitation check all bolts and nuts. The ball of towbar must be always kept clear and conserve with a grease.

Towbar accessories:

Pos. 1 Name: Main bar Quantity: 1 	Pos. 5 Name: Right bracket Quantity: 1 	Pos. 10 Name: Bolt 8,8 B Quantity: 2 Dim.: M12x75mm 	Pos. 15 Name: Plain washer Quantity: 2 Dim.: Ø 13 mm 
	Pos. 6 Name: Left bracket Quantity: 1 	Pos. 11 Name: Bolt 8,8 B Quantity: 4 Dim.: M10x110mm 	Pos. 16 Name: Plain washer Quantity: 8 Dim.: Ø 10,5 mm 
Pos. 2 Name: TOW-ball Quantity: 1 	Pos. 7 Name: Fish-plate Quantity: 2 	Pos. 12 Name: Bolt 8,8 B Quantity: 4 Dim.: M10x35mm 	Pos. 17 Name: Spring washer Quantity: 2 Dim.: Ø 12,2 mm 
Pos. 3 Name: Socket plate Quantity: 1 	Pos. 8 Name: Distance sleeve Quantity: 4 Dim.: Ø17.2x2.35 L=80mm 	Pos. 13 Name: Nut 8 B Quantity: 2 Dim.: M12 	Pos. 18 Name: Spring washer Quantity: 8 Dim.: Ø 10,2 mm 
Pos. 4 Name: Ball cover Quantity: 1 	Pos. 9 Name: Plain washer Quantity: 4 Dim.: Ø37xØ13x3mm 	Pos. 14 Name: Nut 8 B Quantity: 8 Dim.: M10 	



PPUH AUTO-HAK S.J.

Produkcja Zaczepów Kulowych
Henryk & Zbigniew Nejman
76-200 SŁUPSK ul. Słoneczna 16K
tel/fax (059) 8-414-414; 8-414-413
E-mail: office@autohak.com.pl
www.autohak.com.pl

Towing hitch (without electrical set)

Class: **A50-X** Cat. no. **C014**

Designed for:

Manufacturer: **FORD**

Model: **MONDEO**

Type: **4-5 doors**

produced since 1993 till 08.1996

Technical data:

D-value: 8,83 kN

maximum trailer weight: **1800 kg**

maximum vertical cup load: **75 kg**

Approval number according to Directive 94/20/EC: **e20*94/20*0244*00**

Foreword

This towbar is designed according to rules of safety traffic regulations. The towing hitch is a safety component and can be install only by qualified personnel. Any alteration or conversion of the towing hitch is prohibited and would lead to cancellation of design certification. Remove insulating compound and underseal from vehicle (if present) in the area of the matting surfaces of the towing hitch.

The vehicle manufacturer's specifications regarding trailer load and max. vertical cup load are decisive for driving, and values for the towing hitch cannot be exceeded.

D-value formula:

$$\frac{\text{Max trailer weight [kg]} \times \text{Max vehicle weight [kg]}}{\text{Max trailer weight [kg]} + \text{Max vehicle weight [kg]}} \times \frac{9,81}{1000} = D \text{ [kN]}$$