

## FITTING INSTRUCTION

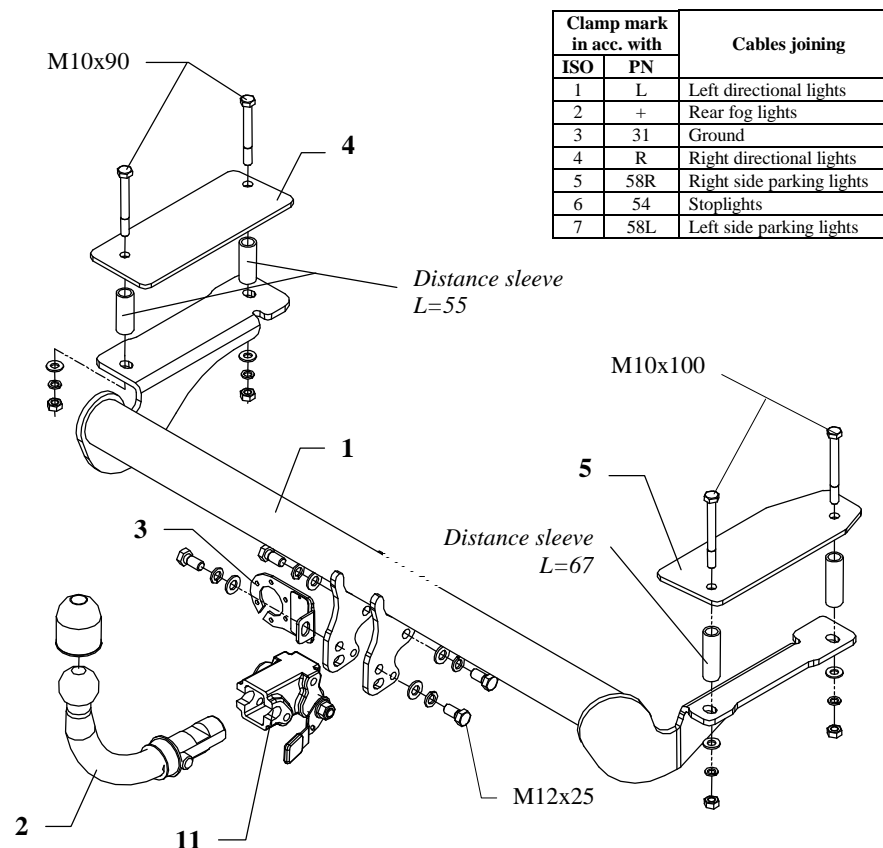

This towbar is designed to assembly in following cars:  
**OPEL ASTRA “B” 4 door** , produced since 10.1998 and **OPEL ASTRA “B” 3/5 door**, produced since 03.1998, catalogue no. **E21A** and is prepared to tow trailers max total weight **1500 kg** and max vertical load **75 kg**.

### *From manufacturer*

Thank you for buying our product. Their reliability has been confirmed in many tests. Reliability of towbar depends also on correct assembly and right operation. For this reasons we kindly ask to read carefully this instruction and apply to hints.

*The towbar should be install in points described by a car producer.*

## The instruction of the assembly

1. Disassemble the bumper and the rear and side panel covers (inside the boot), then draw the fitted carpet back.
2. Find three holes signed on the left and right side, then drill two holes (the first and last one) using a bit  $\varnothing 22$  mm.
3. Put the spacers and the washers (pos. 4 and 5) through these holes, and then put the bolts M10 – see the drawing.
4. Position main bar of the towbar (pos. 1) at the bottom of car, and then fix it using bolts M10 as shown in the figure.
5. Disassemble the foam part from the bumper, then reassemble the bumper.
6. Fix body of the automat (pos. 11) and the socket plate (pos. 3) using bolts M12x25mm (pos. 8) from accessories. Place tow-ball (pos. 2) according to supplied instruction.
7. Tighten all nuts and bolts according to the torque shown in the table.
8. Connect the electric wires according to the instructions of the car.
9. Complete the paint cover of towbar (during the mounting paint cover could be destroyed).

Torque settings for nuts and bolts (8,8):	
<b>M 8</b> - 25 Nm	<b>M 10</b> - 55 Nm
<b>M 12</b> - 85 Nm	<b>M 14</b> - 135 Nm











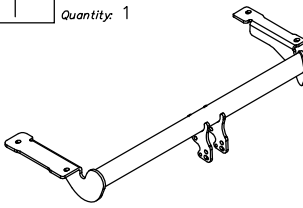

### NOTE

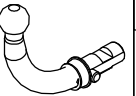
After install the towbar you should get adequate note in registration book (at authorised service station). The car should be equipped with:

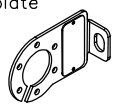
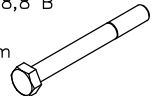
- Indicators
- Tow mirrors

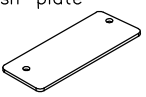
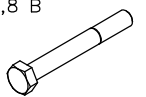
After 1000km check all bolts and nuts. The ball of towbar must be always kept clear and conserve with a grease.

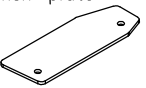
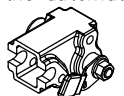
## Towbar accessories:

Pos. 1	Name: Main bar Quantity: 1 	Pos. 6	Name: Distance sleeve Quantity: 2 Dim.: $\varnothing 21,3 \times 2,65 \text{ mm}$ L=55mm 	Pos. 12	Name: Nut 8 B Quantity: 4 Dim.: M10 
		Pos. 7	Name: Distance sleeve Quantity: 2 Dim.: $\varnothing 21,3 \times 2,65 \text{ mm}$ L=67mm 	Pos. 13	Name: Plain washer Quantity: 4 Dim.: $\varnothing 13 \text{ mm}$ 
Pos. 2	Name: Tow ball Quantity: 1 	Pos. 8	Name: Bolt 8,8 B Quantity: 4 Dim.: M12x25mm 	Pos. 14	Name: Plain washer Quantity: 4 Dim.: $\varnothing 10,5 \text{ mm}$ 
Pos. 3	Name: Socket plate Quantity: 1 	Pos. 9	Name: Bolt 8,8 B Quantity: 2 Dim.: M10x100mm 	Pos. 15	Name: Spring washer Quantity: 4 Dim.: $\varnothing 12,2 \text{ mm}$ 
Pos. 4	Name: Left fish-plate Quantity: 1 	Pos. 10	Name: Bolt 8,8 B Quantity: 2 Dim.: M10x90mm 	Pos. 16	Name: Spring washer Quantity: 4 Dim.: $\varnothing 10,2 \text{ mm}$ 
Pos. 5	Name: Right fish-plate Quantity: 1 	Pos. 11	Name: Body of the automat Quantity: 1 	Pos. 17	Name: Ball cover Quantity: 1 



**PPUH AUTO-HAK S. J.**

Produkcja Zaczepów Kulowych  
Henryk & Zbigniew Nejman  
76-200 SŁUPSK ul. Słoneczna 16K  
tel/fax (059) 8-414-414; 8-414-413  
E-mail: [office@autohak.com.pl](mailto:office@autohak.com.pl)  
[www.autohak.com.pl](http://www.autohak.com.pl)

## Towing hitch (without electrical set)

Class: **A50-X** Cat. no. **E21A**

Designed for:

Manufacturer: **OPEL**

Model: **ASTRA B**

Type: **4 door** produced since 10.1998

**3/5 door** produced since 03.1998

Technical data:

**D-value: 8,01 kN**

maximum trailer weight: **1500 kg**

maximum vertical cup load: **75 kg**

Approval number according to Directive 94/20/EC: **e20\*94/20\*1073\*00**

## Foreword

This towbar is designed according to rules of safety traffic regulations. The towing hitch is a safety component and can be install only by qualified personnel. Any alteration or conversion of the towing hitch is prohibited and would lead to cancellation of design certification. Remove insulating compound and underseal from vehicle (if present) in the area of the matting surfaces of the towing hitch. The vehicle manufacturer's specifications regarding trailer load and max. vertical cup load are decisive for driving whereat values for the towing hitch cannot be exceeded.

*D-value formula:*

$$\frac{\text{Max trailer weight [kg]} \times \text{Max vehicle weight [kg]}}{\text{Max trailer weight [kg]} + \text{Max vehicle weight [kg]}} \times \frac{9,81}{1000} = D \text{ [kN]}$$