

## FITTING INSTRUCTION

Clamp mark in acc. with		Cables joining
ISO	PN	
1	L	Left directional lights
2	+	Rear fog lights
3	31	Ground
4	R	Right directional lights
5	58R	Right side parking lights
6	54	Stoplights
7	58L	Left side parking lights

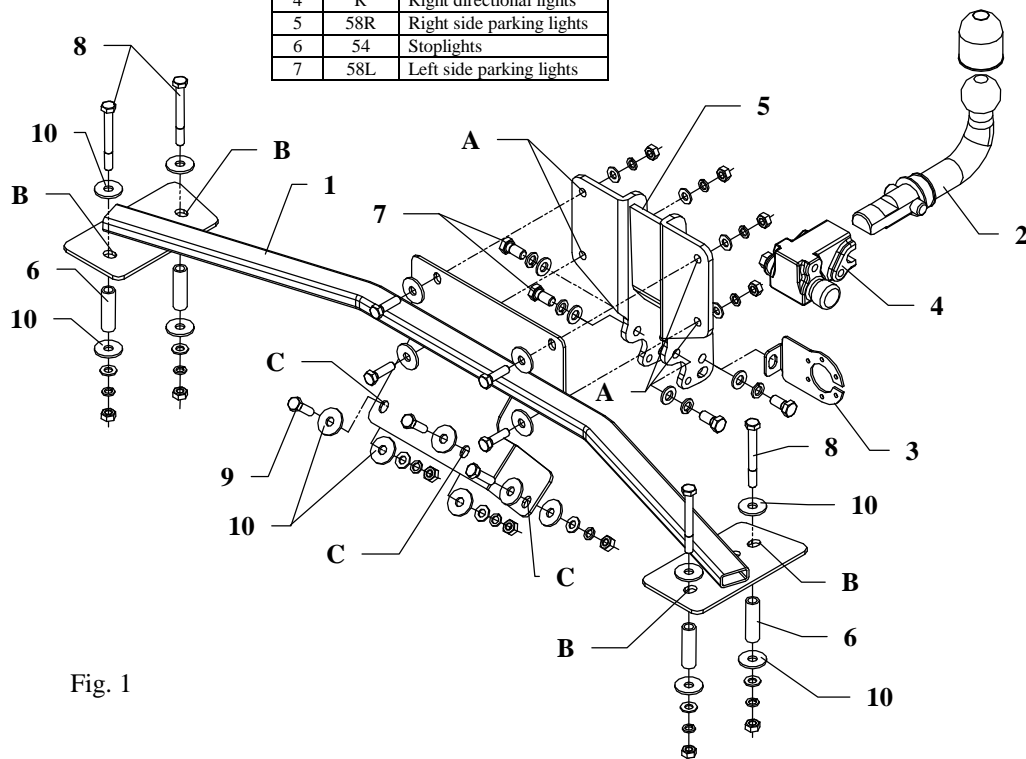

Fig. 1

This towing hitch is designed to assembly in following cars:  
**OPEL ASTRA 'A', 3/5 doors**, produced since 1991 till 2002, catalogue no. **E33A** and is prepared to tow trailers max total weight **1500 kg** and max vertical load **75 kg**.

### *From manufacturer*

Thank you for buying our product. Their reliability has been confirmed in many tests. Reliability of towing hitch depends also on correct assembly and right operation. For this reasons we kindly ask to read carefully this instruction and apply to hints.

*The towing hitch should be install in points described by a car producer.*

## The instruction of the assembly

1. Disassemble the bumper.
2. Drill 4 holes (pos. A) in the rear panel using drill  $\phi 11$ mm.
3. Drill holes (pos. B) in the trunk on the left and right side toward the chassis members using drill  $\phi 11$ mm.
4. Position the main bar of the towing hitch (pos. 1) to the trunk and fix it with the bracket (pos. 5) through the holes (pos. A) using bolts M10x35mm (pos. 9).
5. Position the sleeves L=58mm (pos. 6) at the bottom of the car, and then fix it through the holes (pos. B) using bolts M10x90mm (pos. 8) and large washers (pos. 10).
6. From the trunk side drill holes  $\phi 1$ mm through the towing hitch holes (pos. C) and fix it using bolts M10x35mm (pos. 9) and large washers (pos. 10).
7. Cut the bumper according to fig. 2 and then reassemble it.

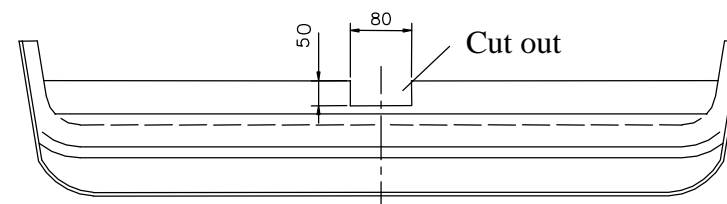

Fig. 2

8. Fix body of the automat (pos. 4) and the socket plate (pos. 3) using bolts M12x25mm (pos. 7) from accessories. Place tow-ball (pos. 2) according to supplied instruction.
9. Tighten all nuts and bolts according to the torque shown in the table.
10. Connect the electric wires according to the instructions of the car.
11. Complete the paint cover of towing hitch (during the mounting paint cover could be destroyed).

Torque settings for nuts and bolts (8,8):	
<b>M 8</b> - 25 Nm	<b>M 10</b> - 55 Nm
<b>M 12</b> - 85 Nm	<b>M 14</b> - 135 Nm











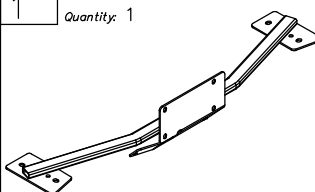
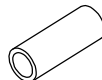

### NOTE

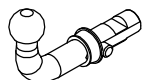
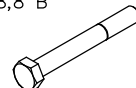
After install the towing hitch you should get adequate note in registration book (at authorised service station).The car should be equipped with:

- Indicators
- Tow mirrors

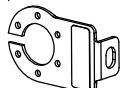
After 1000km of exploitation check all bolts and nuts. The ball of towing hitch must be always kept clear and conserve with a grease.

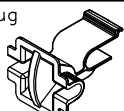
## Towing hitch accessories:

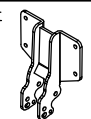
Pos. 1 Name: Main bar Quantity: 1 	Pos. 6 Name: Distance sleeve Quantity: 4 Dim.: $\varnothing 17 \times 2,35 \text{ mm}$ L=58mm 	Pos. 12 Name: Nut 8 B Quantity: 11 Dim.: M10 
	Pos. 7 Name: Bolt 8,8 B Quantity: 4 Dim.: M12x25mm 	Pos. 13 Name: Plain washer Quantity: 4 Dim.: $\varnothing 13 \text{ mm}$ 
Pos. 2 Name: Tow ball Quantity: 1 	Pos. 8 Name: Bolt 8,8 B Quantity: 4 Dim.: M10x90mm 	Pos. 14 Name: Plain washer Quantity: 11 Dim.: $\varnothing 10,5 \text{ mm}$ 
	Pos. 9 Name: Bolt 8,8 B Quantity: 7 Dim.: M10x35mm 	Pos. 15 Name: Spring washer Quantity: 4 Dim.: $\varnothing 12,2 \text{ mm}$ 
Pos. 3 Name: Socket plate Quantity: 1 	Pos. 10 Name: Washer Quantity: 18 Dim.: $\varnothing 35 \times 12 \times 3 \text{ mm}$ 	Pos. 16 Name: Spring washer Quantity: 11 Dim.: $\varnothing 10,2 \text{ mm}$ 
	Pos. 11 Name: Body plug Quantity: 1 	Pos. 17 Name: Ball cover Quantity: 1 
Pos. 4 Name: Body of the automat Quantity: 1 	Pos. 5 Name: Ball bracket Quantity: 1 	



**PPUH AUTO-HAK Sp. J.**

Produkcja Zaczepów Kulowych  
 Henryk & Zbigniew Nejman  
 76-200 SŁUPSK ul. Słoneczna 16K  
 tel/fax (059) 8-414-414; 8-414-413  
 E-mail: [office@autohak.com.pl](mailto:office@autohak.com.pl)  
[www.autohak.com.pl](http://www.autohak.com.pl)

## Towing hitch (without electrical set)

Class: **A50-X** Cat. no. **E33A**

Designed for:

Manufacturer: **OPEL**

Model: **ASTRA "A"**

Type: **3/5doors**

produced since 1991 till 2002

Technical data:

**D-value: 7,67 kN**

maximum trailer weight: **1500 kg**

maximum vertical cup load: **75 kg**

Approval number according to Directive 94/20/EC: **e20\*94/20\*1064\*00**

## Foreword

This towing hitch is designed according to rules of safety traffic regulations. The towing hitch is a safety component and can be install only by qualified personnel. Any alteration or conversion of the towing hitch is prohibited and would lead to cancellation of design certification. Remove insulating compound and underseal from vehicle (if present) in the area of the matting surfaces of the towing hitch. The vehicle manufacturer's specifications regarding trailer load and max. vertical cup load are decisive for driving whereat values for the towing hitch cannot be exceeded.

*D-value formula:*

$$\frac{\text{Max trailer weight [kg]} \times \text{Max vehicle weight [kg]}}{\text{Max trailer weight [kg]} + \text{Max vehicle weight [kg]}} \times \frac{9,81}{1000} = D \text{ [kN]}$$