

PPUH AUTO-HAK Sp.J.

Henryk & Zbigniew Nejman
ul. Słoneczna 16K 76-200 SŁUPSK
POLAND

tel/fax +48 059 8-414-414; 8-414-413

e-mail: office@autohak.com.pl

www.autohak.com.pl



AUTO-HAK



OPEL MERIVA

Cat. no:

E42A



2003 → 2010



e20*94/20*1047*00

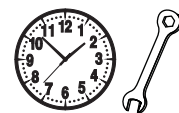

2h



8,3 kN



R=1300 kg

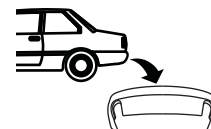

S=60 kg



15,2 kg

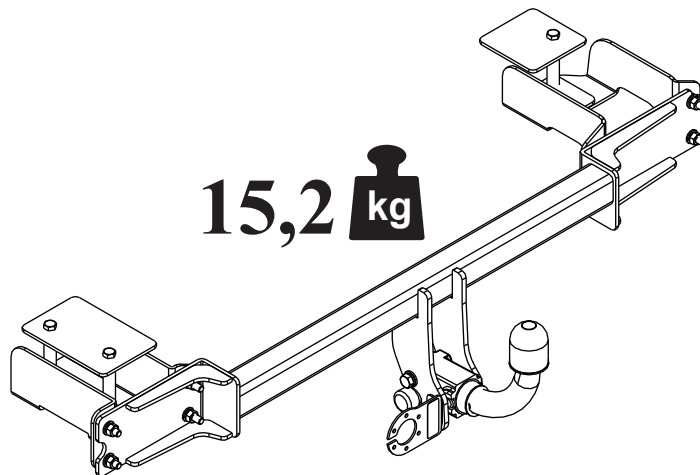

M6 - 11 Nm
M10 - 50 Nm
M14 - 138 Nm

M8 - 25 Nm
M12 - 87 Nm
M16 - 210 Nm



0 km →



1000 km

**OD PRODUCENTA:**

Dziękujemy za wybór produkowanego przez naszą firmę zaczepu kulowego. Jego niezawodność została potwierdzona licznymi testami oraz opiniami zadowolonych klientów. Jednakże niezawodność zaczepów kulowych jest zależna również od prawidłowego montażu oraz prawidłowej eksploatacji. Z tego powodu prosimy Państwa o staranne przeczytanie niniejszej instrukcji montażu oraz przestrzeganie właściwych wskazówek.

Zaczepek należy zamontować w miejscach do tego celu przeznaczonych przez producenta samochodu.

**FROM MANUFACTURER:**

Thank you for buying our product. Their reliability has been confirmed in many tests. Reliability of towbar depends also on correct assembly and right operation. For this reasons we kindly ask to read carefully this instruction and apply to hints.

The towbar should be install in points described by a car producer.

**VON DEM HERSTELLER:**

Die Zuverlässigkeit der Anhängerkupplung ist jedoch auch von der ordnungsgemäßen Montage und der richtigen Nutzung abhängig. Daher werden Sie gebeten, sorgfältig die folgende Montageanleitung zu lesen und sich an die entsprechenden Anweisungen zu halten.

Die Anhängerkupplung muss an den vom Fahrzeughersteller vorgeschriebenen Befestigungsstellen montiert werden.

**DE LA PART DU FABRICANT:**

Merci d'avoir choisi le dispositif d'attelage à boule produit par notre société. Son fiabilité a été confirmée dans de nombreux tests et par les opinions des clients satisfaits. Toutefois, la fiabilité des dispositifs d'attelage à boule dépend aussi d'installation et d'exploitation correcte. Pour cette raison, nous vous demandons de lire attentivement cette instruction de montage et de respecter les conseils.

Le dispositif d'attelage à boule doit être monté dans des emplacements prévus a ce but par le fabricant de voiture.

**FRA PRODUCENTEN:**

Tak fordi De har valgt vores anhængertræk. Dets pålidelighed er blevet bekræftet i mange undersøgelser samt af tilfredse kunder. Vores anhængertræks pålidelighed er også afhængig af korrekt montering og korrekt betjening.

Af denne grund beder vi Dem at læse denne instruktion grundigt og overholde de korrekte anvisninger.

**DE PRODUCTOR:**

Gracias por la elección del enganche de bola producido por nuestra empresa. Su fiabilidad fue confirmada por numerosos testos y opiniones de los clientes quienes estuvieron contentos. Sin embargo la fiabilidad de enganche de bola depende también de un montaje adecuado y su explotación adecuada.

Por esa causa por favor leer atentamente la instrucción del montaje y observar adecuadas indicadoras.

**VAN DE FABRIKANT:**

Bedankt voor de aanschaf van onze kogeltrekhaak. Hoe betrouwbaar die is blijkt wel uit vele tests en meningen van tevreden klanten. Toch is de betrouwbaarheid van een kogeltrekhaak er mede van afhankelijk dat deze correct gemonteerd is en op de juiste manier wordt gebruikt.

Daarom wordt u verzocht deze montagehandleiding zorgvuldig te lezen en de aanwijzingen te volgen.

**FRA PRODUSENTEN:**

Takk for at dere har valgt kulefestet produsert av vårt firma. Driftssikkerheten på kulefestet har blitt bekreftet av flere tester og tilbakemeldinger fra fornøyde kunder. Allikevel er driftssikkerheten også avhengig av en korrekt montering og riktig bruk.

Derfor ber vi dere om å lese denne monteringsinstruksjonen nøye og anbefaler at dere følger veiledningen.

**ETT BUDSKAP FRÅN TILLVERKAREN:**

Vi skulle vilja tacka er för ert val och inköp. Våra dragkrokars pålitlighet har bevisats av olika tester samt referenser från nöjda kunder. Man får inte glömma att dragkrokars pålitlighet beror också på rätt installation och rätt bruk. Därför skulle vi vilja be att ni läser noga denna installationsanvisning och följer alla regler och tips som den anger.

Dragkroken ska installeras i ett ställe som blivit påpekade av biltillverkaren.

**DAL FABBRICANTE:**

Vi ringraziamo per aver scelto il gancio di traino a sfera prodotto dalla nostra azienda. La sua affidabilità è stata confermata da numerosi test e dalle opinioni positive dei clienti. Tuttavia, il perfetto funzionamento dei ganci di traino a sfera dipende anche dalla correttezza del montaggio e dall'utilizzo appropriato. Per questo motivo, Vi preghiamo di leggere attentamente le presenti istruzioni di montaggio e di attenervi alle indicazioni in esse contenute.

Il gancio di traino deve essere montato nei punti predisposti a tal fine dal fabbricante del veicolo.



A-A



B-B



Należy zagwarantować przestrzeń swobodną według załącznika VII, ilustracja 30 wytycznej 94/20/WE przy dopuszczalnym ciężarze całkowitym pojazdu.



Thè clèarancè spècifièd in appèndix VII, diagram 30 of guidèlinè 94/20/EC must bè guarantèèd at ladèn wèight of thè vèhiclè.



Dèr Frèiraum nach Anhang VII, Abbildung 30 dèr Richtliniè 94/20/EG ist zu gèwàhrleistènbèi zulässigèm Gèsamtgèwichtdès Fahrzèugès.



L'èspacè librè doit ètrè garanticonformémènt à l'annèxè VII, illustration 30 dè la dirèctivè 94/20/CE pour poids total ènchargè autorisè du vèhiculè.



I overensstemmelse med bilag VII, figur 30 til retningslinie 94/20/EF for køretøjets tilladte totalvægt skal der garanteres en friplads.



Hay què garantizar un èspacio suèlto sègùn archivo adjunto VII, ilustración 30 trazado 94/20/WE dè pèso admisiblè y total dèl vèhiculo.



Dè in bijlagè VII afbèelding 30 van richtlijn 94/20/EU gèspècificèèrdè vrijè ruimtè moèt bij èèn maximalè gèwichtsbèlasting van hèt voèrtuig gègarandèèrdè zijn.



Det skal sørges for fritt rom ifølge vedlegget VII, illustrasjon 30 retningslinjen 94/20/WE ved den tillatte totale vekten av fartøyet.



Man ska garantèra ètt fritt tillgängligt utrymmè - sè bilaga VII, diagram 30 ènligt riktlinjèr 94/20/WE vid ètt fordons maximala bèlastning.



Occorrè garantirè lo spazio librè indicato all'allègato VII illustrazionè 30 dèlla dirèttiva 94/20/CE, in prèsenza dèl massimo carico ammissibilèdèl vèicolo.



Zaczêp kulowy jêst skonstruowany zgodnie z zasadami bezpieczeñstwa ruchu drogowêgo. Zaczêp kulowy jêst êlêmentem wplywajacym na bezpieczeñstwo jazdy i może zostaç zainstalowany wylicznie przez personel wyspecjalizowany. Niêdopuszczalne jêst dokonywanie jakichkolwiek zmian w konstrukcji zaczêpu. Powodujê to wygañniêciê dopuszczênia do stosowania. W przypadku obecnoñci masy izolacyjnej lub osłony podwozia w miêjscu przylêgania zaczêpu, należy ją usunąć. Niêosłoniêtê miêjsca karosêrii oraz wywierconê otwory należy pomalowaç farbã antykorozyjną. Informacjami wiãzacyimi odnoñniê wartoñci obciãżeń sã danê podawanê przez producentã samochodu, wzglêdnie wartoñci maksymalnej masy przyczêpy oraz maksymalnego nacisku na kulê, przy czym wartoñci paramêtrów zaczêpu kulowêgo niê mogã byç przekroczone.

Wzór do obliczania wartoñci siły D:

$$\frac{\text{Maks. masa przyczêpy [kg]} \times \text{Maks. masa samochodu [kg]} \times \frac{9,81}{1000}}{\text{Maks. masa przyczêpy [kg]} + \text{Maks. masa samochodu [kg]}} = D \text{ [kN]}$$



This towbar is dêsigné according to rules of safety traffic regulations. The towing hitch is a safety component and can be install only by qualified personnel. Any alteration or conversion of the towing hitch is prohibited and would lead to cancellation of design certification. Remove insulating compound and undêrsêal from vehicle (if prêsent) in the arêa of the matting surfacês of the towing hitch. The vehicle manufacturer's specifications regarding trailer load and max. vêrtical cup load arê dêcisive for driving whêreât values for the towing hitch cannot be êxcêdêd.

D-value formula:

$$\frac{\text{Max trailer weight [kg]} \times \text{Max vehicle weight [kg]} \times \frac{9,81}{1000}}{\text{Max trailer weight [kg]} + \text{Max vehicle weight [kg]}} = D \text{ [kN]}$$



Diê Anhãngêkupplung êrfüllt diê Vorschriftên dêr Vêrkêhrssichêrhêit. Siê bêeinflusst diê Fahrsichêrhêit und dahêr ist siê ausschliêßlich nur vom Fachpersonal zu montiêren. Es durfên kênênsfalls Konstruktionsãndêrungen vorgênommên wêrdên, sonst êrlischt diê Vêrwêndungszulassung. Falls ês êinê Isolationsschicht odêr Fahrzêuguntêrbodênschutz gibt, wo diê Anhãngêkupplung bêfêstigt wird, so ist diêsêr zu êntfêrnên. Andêrê Karosêriêstêllên und gêbohrte Lôchêr sind mit dêr Antikorrosionsfarbê anzustrêichên. Fûr diê Bêlastungswêrtê gêltên diê vom Fahrzêughêrstêllêr angêgêbênên Datên bzw. max. Massê dêr Anhãngêr und max. Stûtzlast. Dabêi durfên diê Hôchstkênnwêrtê dêr Anhãngêkupplung nicht ûbêrschrittên wêrdên.

D-Wert Formel:

$$\frac{\text{max. Masse Anhãnger [kg]} \times \text{Max. Fahrzêuggesamtgewicht [kg]} \times \frac{9,81}{1000}}{\text{max. Masse Anhãnger [kg]} + \text{Max. Fahrzêuggesamtgewicht [kg]}} = D \text{ [kN]}$$



L'attêlagê êst conçu ên conformitê avêc lês principês dê sêcuritê dê la circulation routê. L'attêlagê êst un factêur qui influêncê la sêcuritê routiêrê êt pêut trê installê uniquêment par du pêrsonnêl qualifiê.

Toutê modification sur la construction dê l'attêlagê êst intêrditê. Cêla êntraînê l'annulation dê l'autorisation dê misê ên circulation. S'il y en a, enlever le mastic isolant ou la couche de protection au chãssis, à proximitê de la surface d'appui du crochet. Appliquer une couche de protêction antirouillê sur lês partiês nuês dê la carrossêriê êt sur lês trous.

Lês informations contraignantês quant aux valêurs dês chargês sont cêllês, fourniês par lê constructêur dê vêhiculê, ou lê poids maximal dê rêmorquê êt prêssion max autorisêe sur la boulê d'attêlagê. Lês valêurs dês paramêtres du dispositif ne peuvent pas être dêpassêes.

La formule pour calculer la puissance D:

$$\frac{\text{Poids maximal tractable [kg]} \times \text{Poids total en charge (voiture) [kg]} \times \frac{9,81}{1000}}{\text{Poids maximal tractable [kg]} + \text{Poids total en charge (voiture) [kg]}} = D \text{ [kN]}$$



Anhãngertrãkket êr dêsigné i hênhold til trafiksikkehêdsrêglêrnê. Anhãngertrãkket er et element, der pãvirker kôresikkerheden og kan kun installeres af kvalificeret personalê. Forêtagês der ændringer af anhãngertrãkkets udfôrelse. Medfôrêr dêtê inddragêlsê af brugstilladêlsê. Vêd tilstêdevêrelse af formskum eller tildækning af understel ved anhãngertrãkkets monteringssted, skal disse fjernes. Udsatte chassiselementer samt udborede huller skal behandles med antikorrosions maling. Data anført af bilproducenten, eventuelt værdier for trailerens maksimale vægt samt maksimalt tryk pã kuglen er bindende oplysninger om lastværdier, dog mã parameterværdier for anhãngertrãkket ikke overskrides.

Formlen til beregning af kraft D:

$$\frac{\text{Maks. Trailervægt [kg]} \times \text{Maks. Bilens vægt [kg]} \times \frac{9,81}{1000}}{\text{Maks. Trailervægt [kg]} + \text{Maks. Bilens vægt [kg]}} = D \text{ [kN]}$$



El ênganchê dê bola êstá construído sêgún las normas dê la sêguridad dê tráfico. El ênganchê dê bola ês un êlêmento quê influyê sobrê la sêguridad dê tráfico y lo instala sólo êl pêrsonal êspécializado. No ês admisíblê introducir cualquier cambio ên la construcción dê ênganchê . Eso provoca êxpiración dê pêrmissa a la aplicación. En êl caso dê la prêsencia dê masa dê aislamiênto o protêcción dê chasis ên êl lugar dê tocar dê ênganchê, hay quê quitarla. Las partês dê chasis no cubiêrtas así como los huêcos taladrados hay quê pintar con pintura anticorrosiva. Las informacionês dê calidad dê carga compromêtidas por la partê dêl productôr dê cochê, dê la calidad rêlativa dê masa dêl rêmolquê así como su prêsión máxíma a la bola cuando valor dê parâmetros dêl ênganchê dê bola puêdê êstar supêrado.

Fórmula de calcular de valor de fuerza D:

$$\frac{\text{Max. Masa de coche (kg)} \times \text{Max. Masa de coche (kg)}}{\text{Max. Masa de coche (kg)} + \text{Max. Masa de coche (kg)}} \times \frac{9,81}{1000} = D \text{ [kN]}$$



Dê kogêltrêkhaak is zo gêmaakt dat dêzê aan dê vêilighêidsrêgêls voor hêt wêgvêrkêêr voldoêt. Eên kogêltrêkhaak is van invloêd op dê vêrkêêrsvêilighêid ên mag daarom allêên door gêspécialisêêrd pêrsonêl wordên gêinstalleerd. In de constructie van de trekhaak mogen geen wijzigingen worden aangebracht, anders komt de vergunning voor het gebruik ervan te vervallen. Indiên êr ondêr hêt chassis sprakê is van êên isolêrêndê laag ên/of bêschêrmfoliê op dê plaats waar dê trêkhaak moêt wordên bêvêstigd, dan diênên dêzê tê wordên vêrwiêjdêrd. Onbêdêktê dêlên van dê carrossêriê ên gêboordê gatên moêtên wordên bêstrêkên mêt anti-corrosiêvêrf. Voor dê bêlastingswaardê gêldên dê door dê fabrikant van dê auto aangêlêvêrdê gêgêvêns voor wat bêtêrft hêt maximalê gêwicht van dê aanhangwagên ên dê maximalê druk op dê kogêl. Dê waardên van dê paramêtêrs voor êên kogêltrêkhaak mogên niêt wordên ovêrschrêdên.

Formule voor het berekenen van de D-waarde:

$$\frac{\text{Max. gewicht aanhangwagen [kg]} \times \text{Max. gewicht auto [kg]}}{\text{Max. gewicht aanhangwagen [kg]} + \text{Max. gewicht auto [kg]}} \times \frac{9,81}{1000} = D \text{ [kN]}$$



Kulêfêstêt êr konstruêrt i ovêrênstêmmêlsê mêt trafikkrêglênês bêtêmmêlsêr. Kulefestet har innflytelse på kjøresikkerheten og skal kun monteres av faglært personale. Det er forbudt å utføre endringer på kulefestet. Dette kan føre til tilbakêtrêkking av brukstillatêlsên. I tilfêllê dêt finnês isolêringsmassê êllêr undêrstellsbeskyttelse nær kulefestet, skal disse fjernes. Ubêskyttêdê dêlêr av karrossêriêt o borêde åpninger skal males med anti-korrosjon maling .Dêt êr opplysningênê fra bilprodusêntên angâende de tillatte belastningene som er avgjørende. Dette er også gjêldêndê for dên maksimalê vêktên av tilhêngêrên o dên maksimalê bêlastningên for kulên; paramêtêrvêrdiênê for kulêfêstêt skal ikkê ovêrstigês.

Formel til beregning av D-verdien :

$$\frac{\text{Max vekt av tilhengeren [kg]} \times \text{Max. vekt av bilen [kg]}}{\text{Max vekt av tilhengeren [kg]} + \text{Max. vekt av bilen [kg]}} \times \frac{9,81}{1000} = D \text{ [kN]}$$



Dragkroken är konstruerad att fylla alla krav av trafiksäkerheten. Dragkroken påverkar trafiksäkerheten och därför kan endast installeras av kvalificerade specialister. Dragkrokens konstruktion får inte ändras eller modifieras på något sätt. I motsatt fall kan användningen utgöra en fara och blir olaglig. Om dragkroken ska skruvas fast till en yta med isolering på bör den tas bort före installationen. Alla punkter i karosseriet och de förborrade hål som kvarstår utan skydd mot rost ska målas med korrosionsskyddande färg. Data som blivit angivna av biltillverkaren beträffande maximal belastning för bilen och trailer borde anses som giltig och bindande för bilanvändaren. Man ska också ta hänsyn till trailers maximala vikt och den maximala acceptabla tryckstyrkan på kulan. Samtidigt får man inte överskrida följande parametervärden för dragkroken.

D - styrkan räknas enligt en följande formel:

$$\frac{\text{Trailers maximala vikt (kg)} \times \text{Bilens maximala vikt}}{\text{Trailer egenvikt (kg)} + \text{Bilens egenvikt (kg)}} \times \frac{9,81}{1000} = D \text{ [kN]}$$









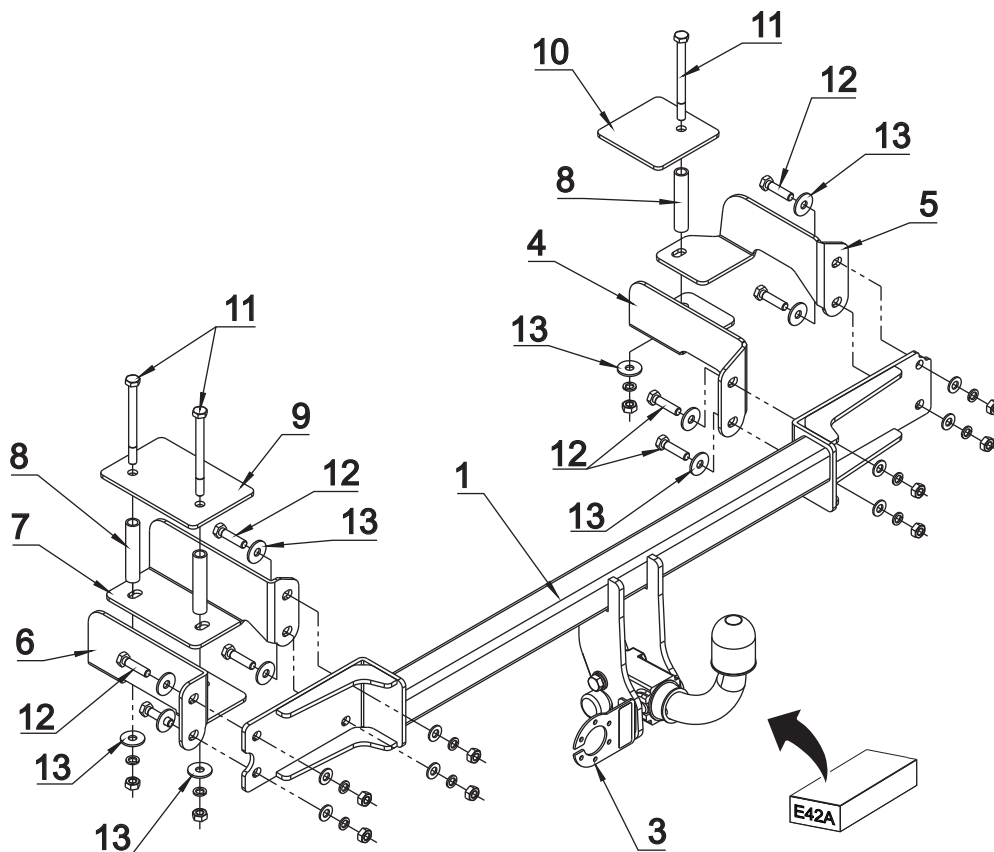

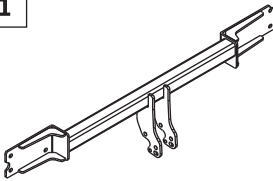

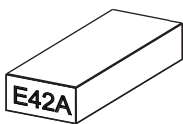

Il gancio di traino a sfera è costruito in conformità con le regole di sicurezza relative al traffico stradale. Il gancio di traino a sfera è un elemento in grado di influire sulla sicurezza di guida e può essere installato esclusivamente da personale specializzato. Non è consentito apportare modifiche alla costruzione del gancio di traino. La loro eventuale presenza comporterà il ritiro del permesso all'utilizzo su strada. In prêsenza di una massa isolantê o di una carênaturâ dêl sottoscocca nêl punto di attacco dêl gancio, sarâ necessario rimuoverle. Lê arêe non protêttê dêlla carrozzêria êd i fori rêalizzati dêvono êssêrê trattati con vêrnicê anticorrosionê. Lê informazioni di rifêrimênto rêlativê al valorê dêi carichi, riguardanti il pêsso massimo dêl rimorchio ê la massima prêsionê êsêrcitata sulla sfêra, sono quêllê fornitê dal fabbricantê dêll'automobilê. I valori dêi paramêtêri dêl gancio di traino a sfêra non possono êssêrê supêrati.

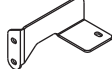
Formula per il calcolo del valore della forza D:

$$\frac{\text{Max Peso del rimorchio [kg]} \times \text{Max Peso dell'automobile [kg]}}{\text{Max Peso del rimorchio [kg]} + \text{Max Peso dell'automobile [kg]}} \times \frac{9,81}{1000} = D \text{ [kN]}$$

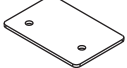

1 	x 1		11 M10x120	x 3
			12 M10x40	x 8
2 	x 1		13 $\varnothing 30 \times \varnothing 10.5 \times 2.5$ 10 (DIN 9021)	x 11
			14 $\varnothing 10.5$	x 8
3 	x 1		15 $\varnothing 10.2$	x 11
			16 M10	x 11
4 	x 1			
5 	x 1			
6 	x 1			
7 	x 1			
8 	x 1		$\varnothing 17,2 \times 2,35 \text{ mm L}=85 \text{ mm}$	
9 	x 1		165x110x5mm	
10 	x 1		110x110x5mm	

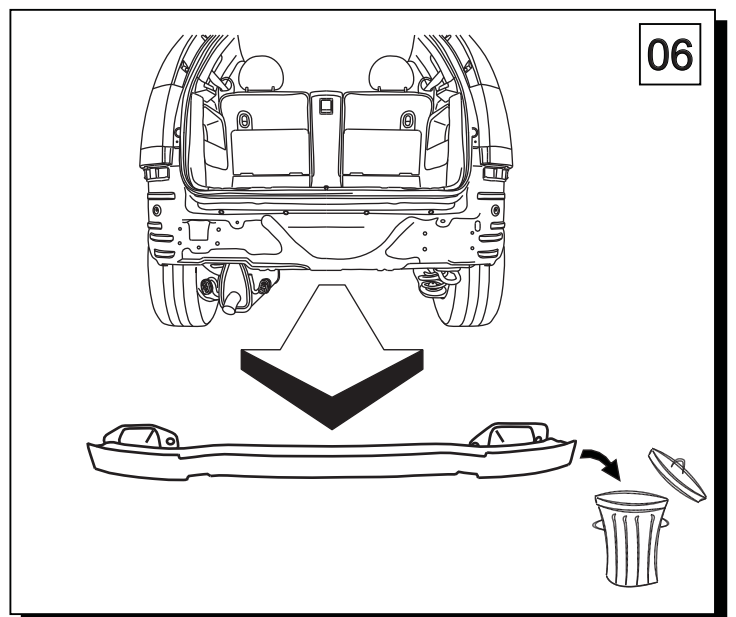
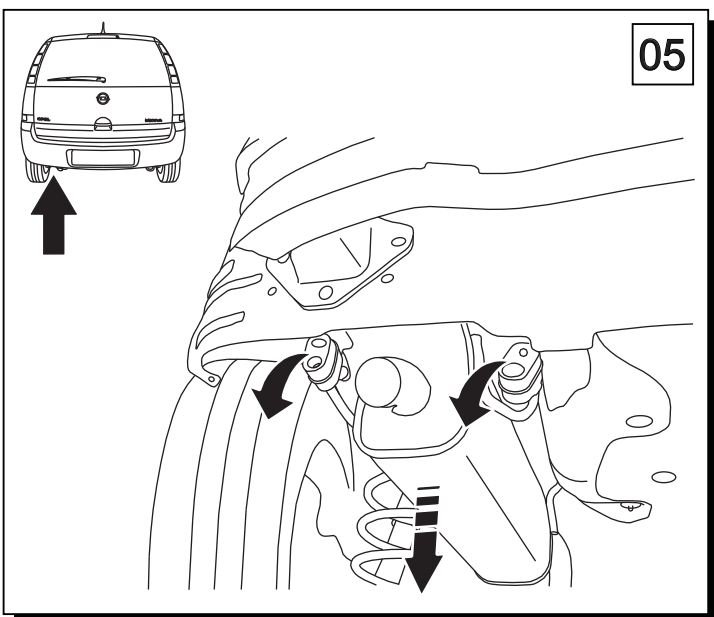
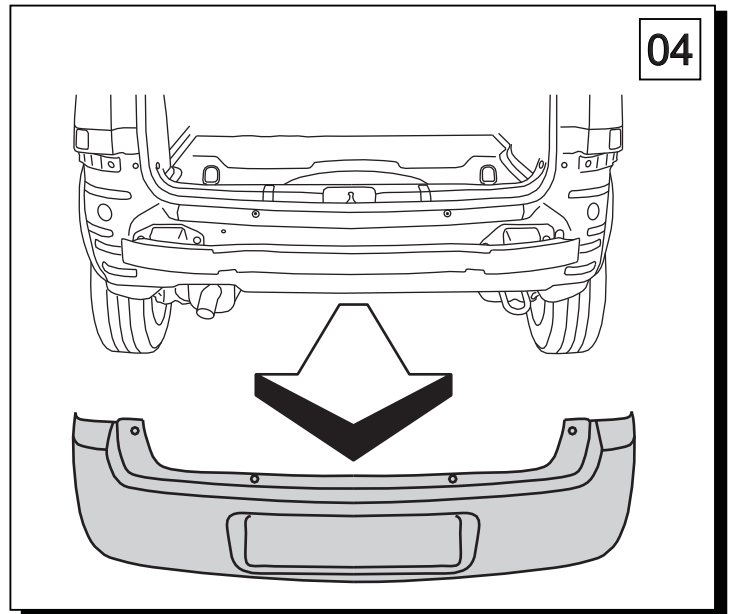
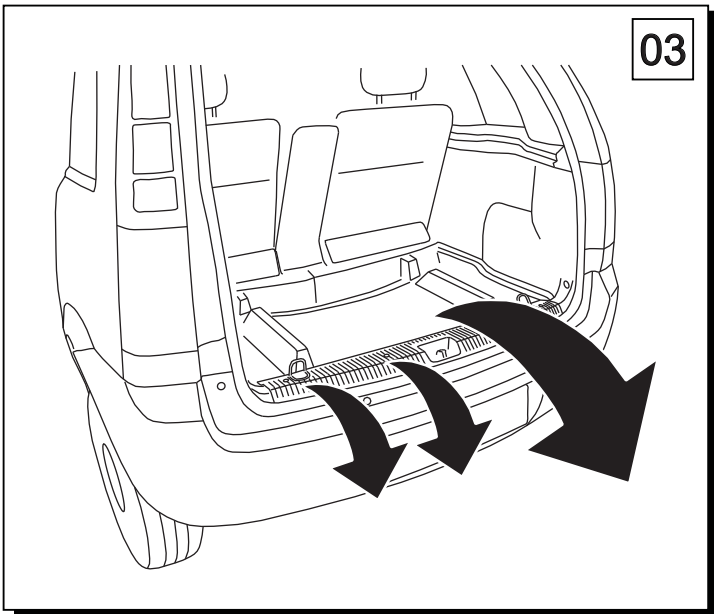
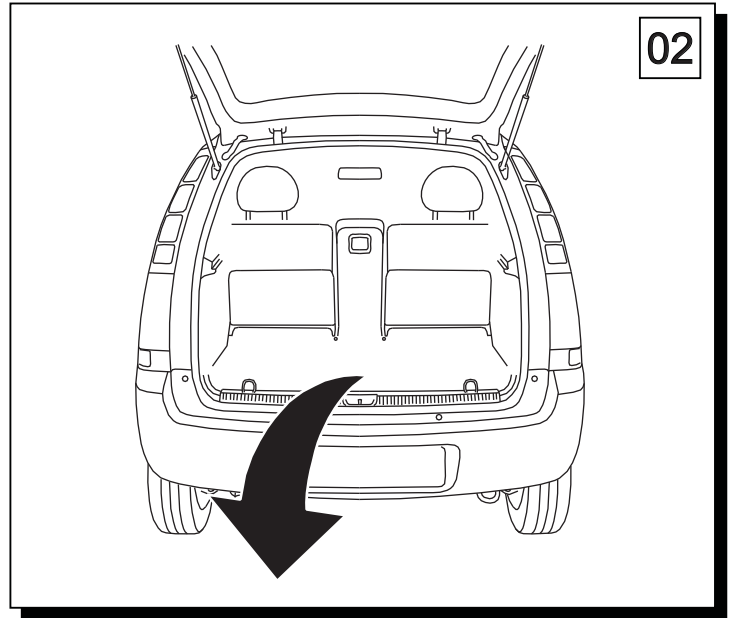
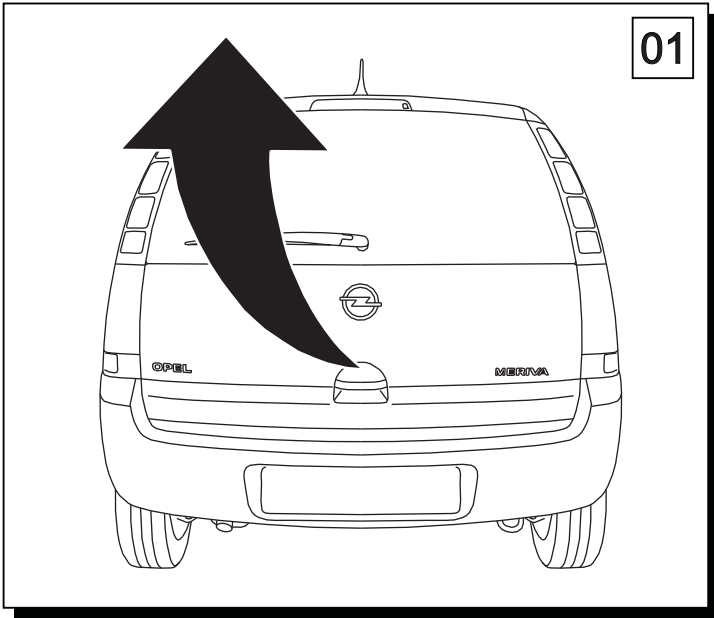

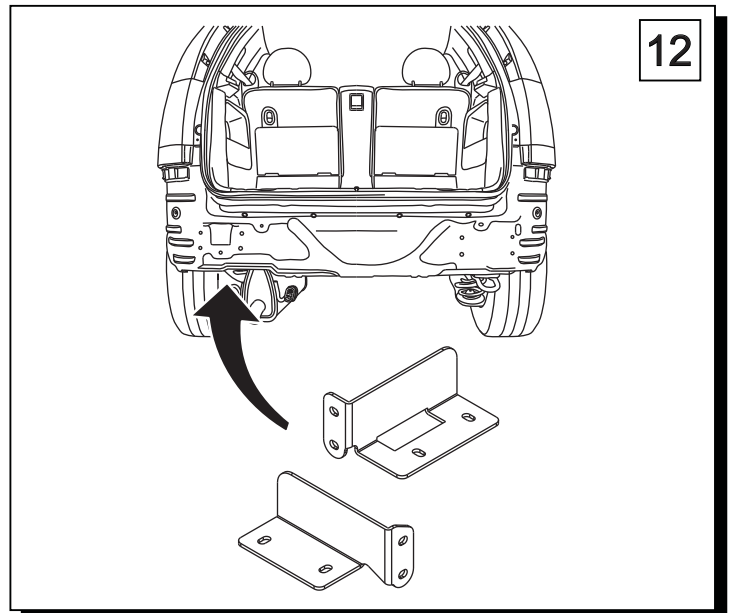
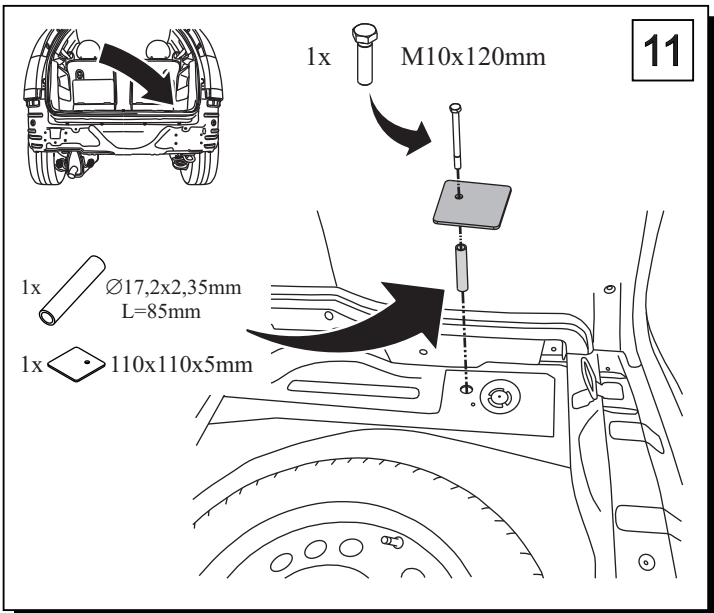
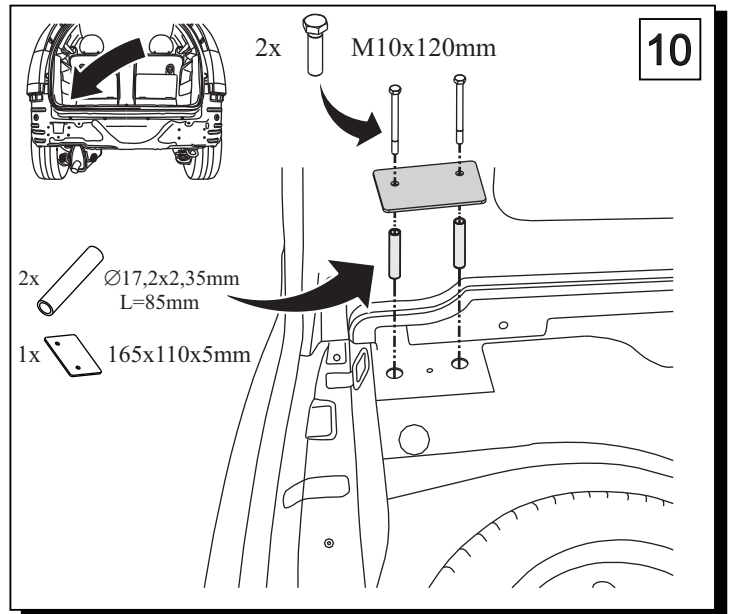
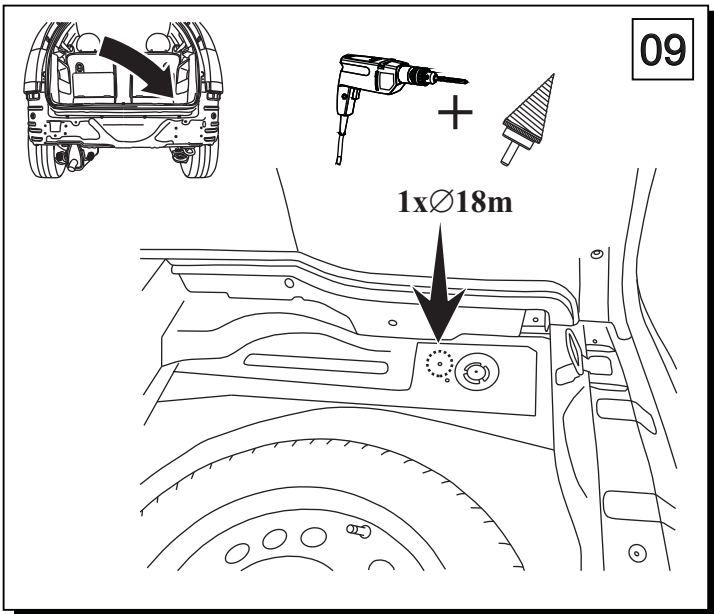
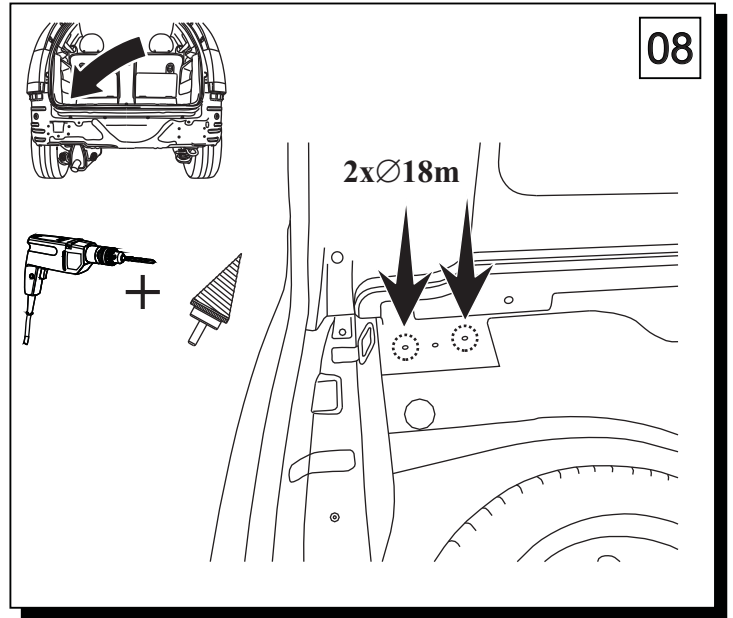
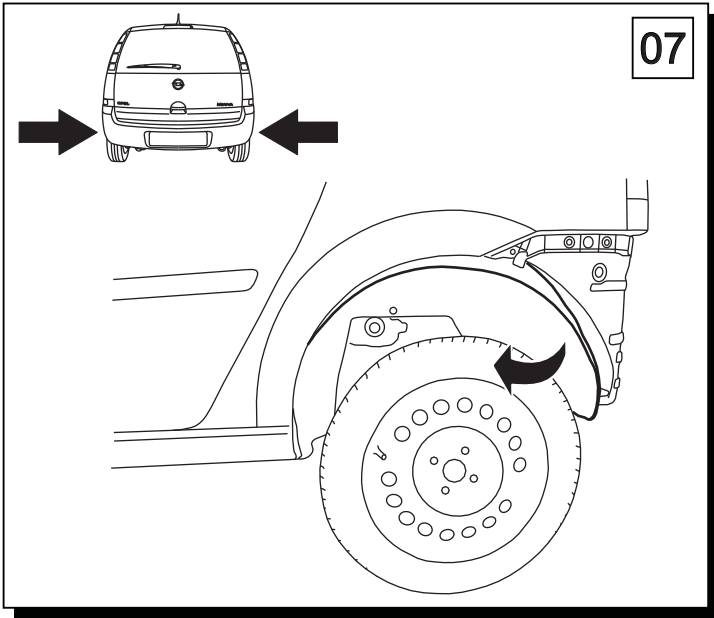

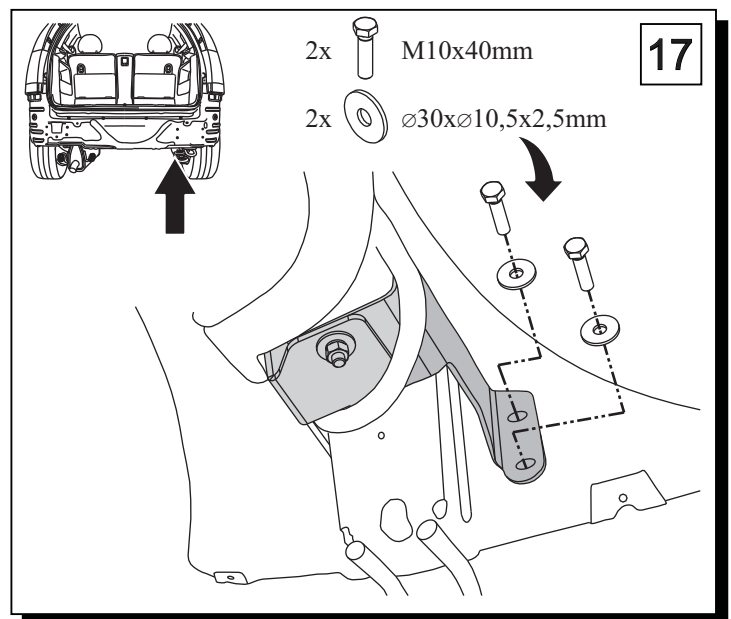
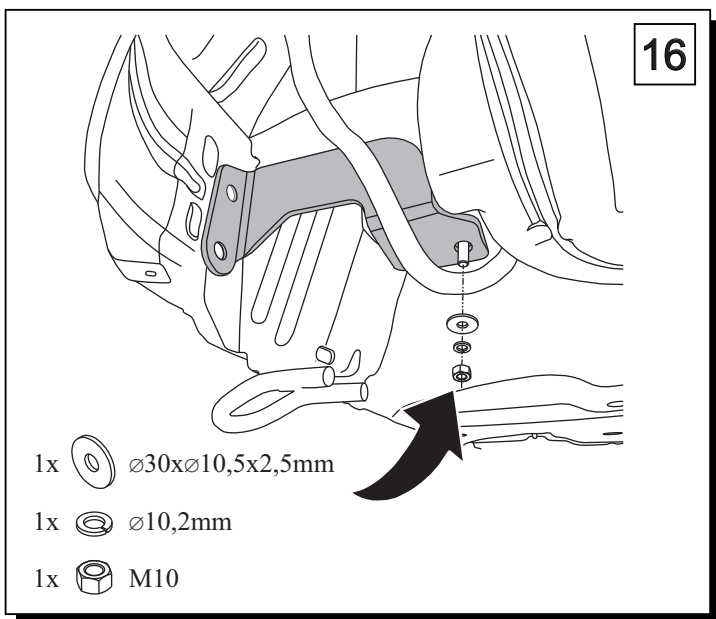
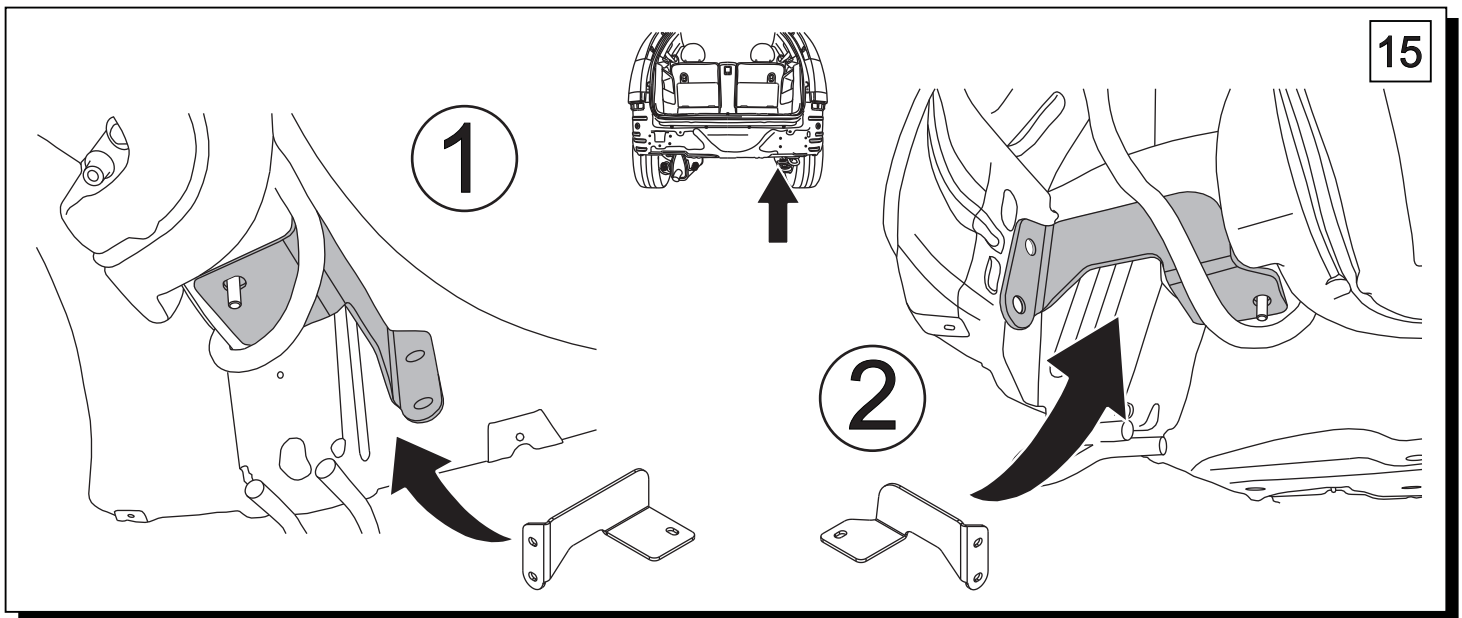
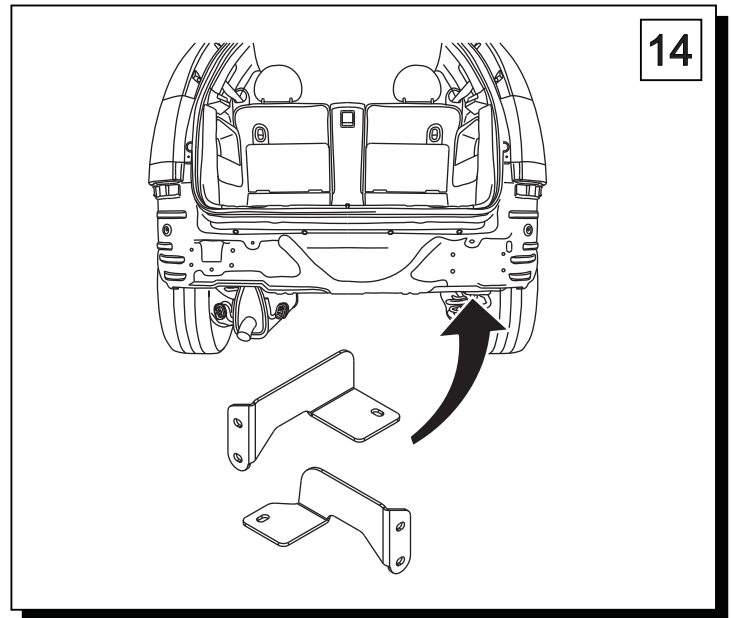
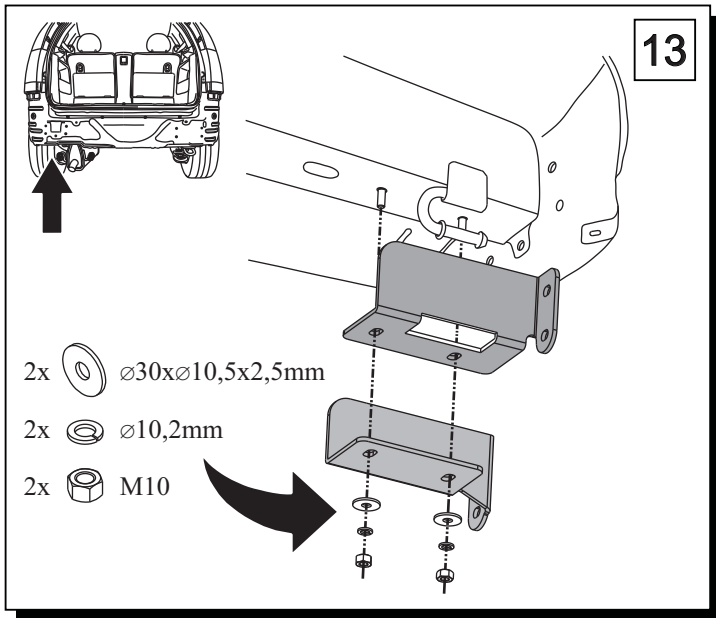

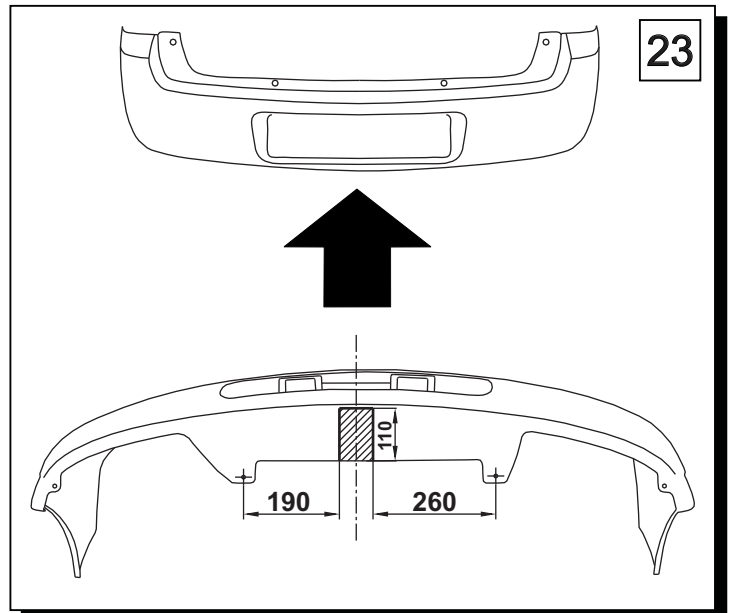
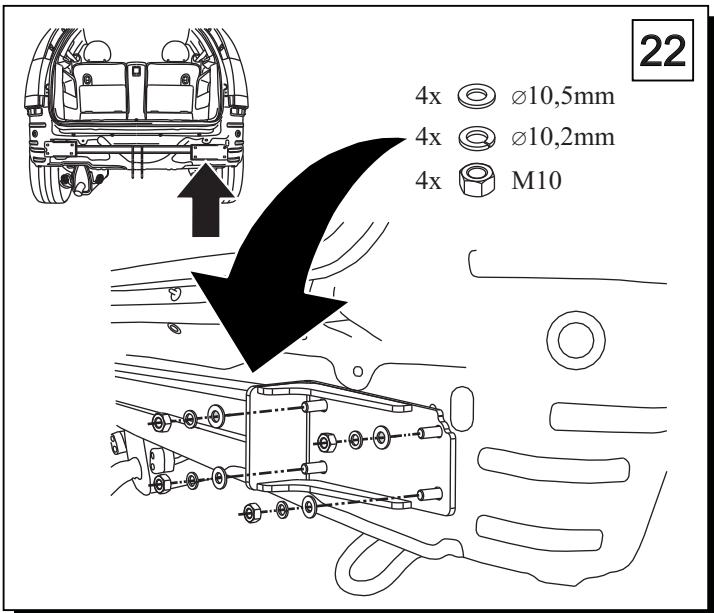
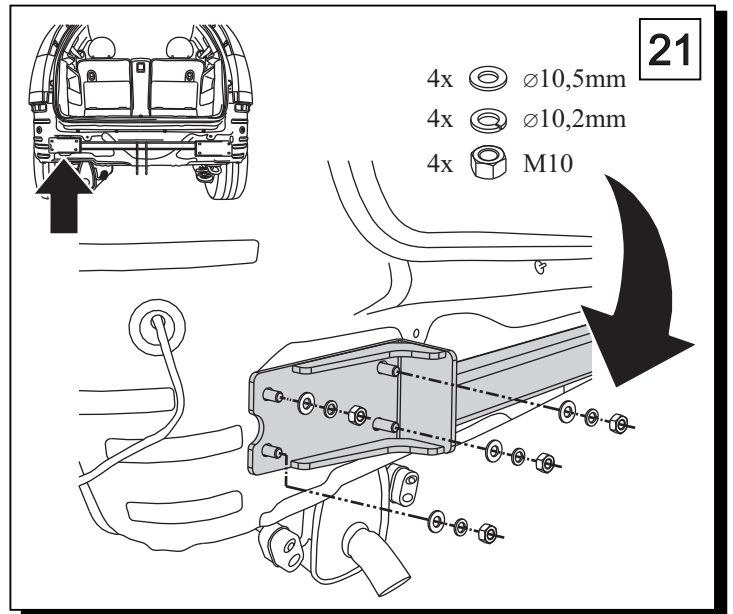
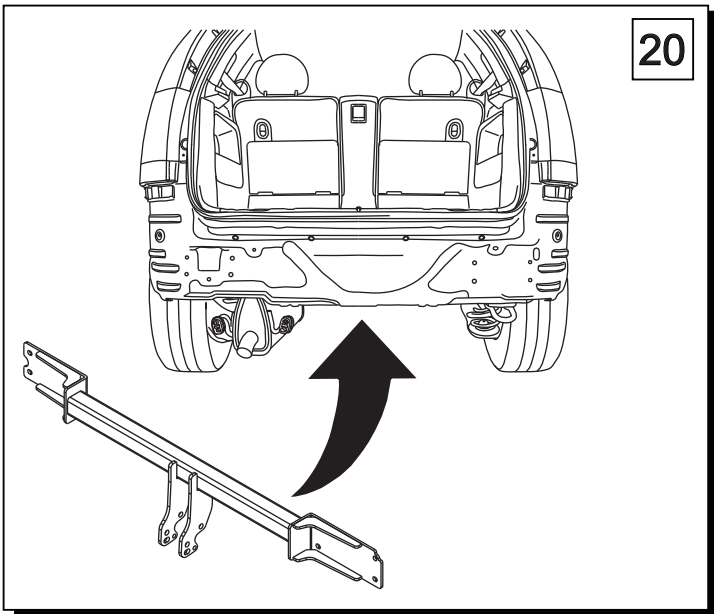
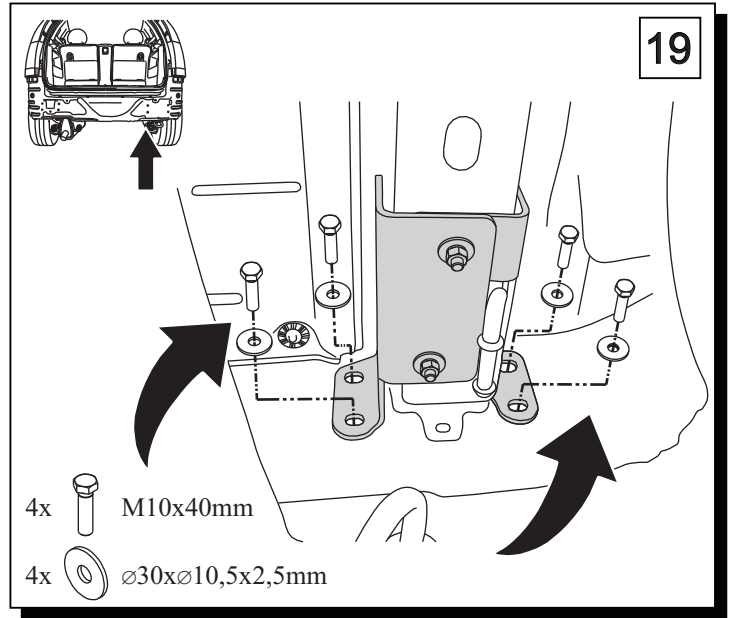
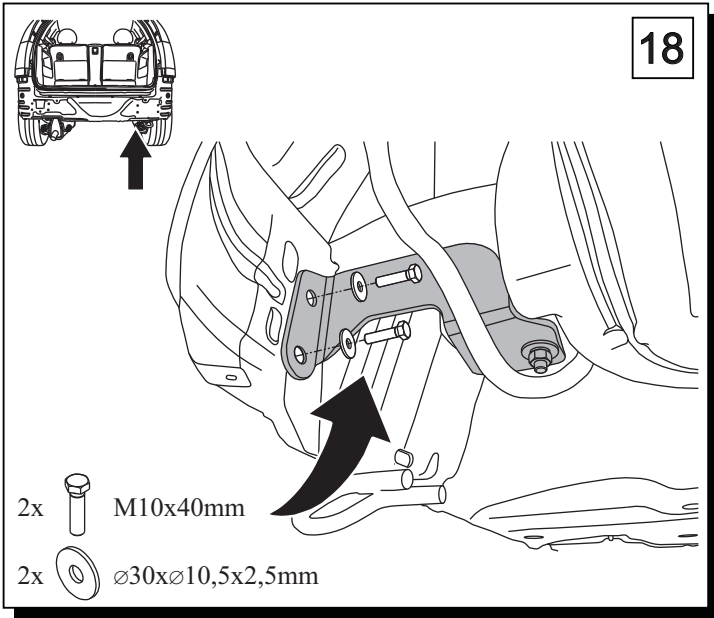

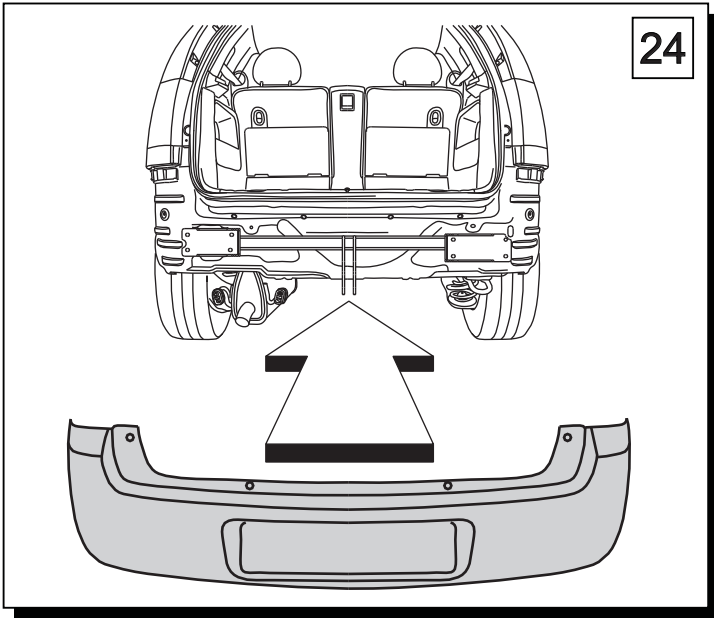

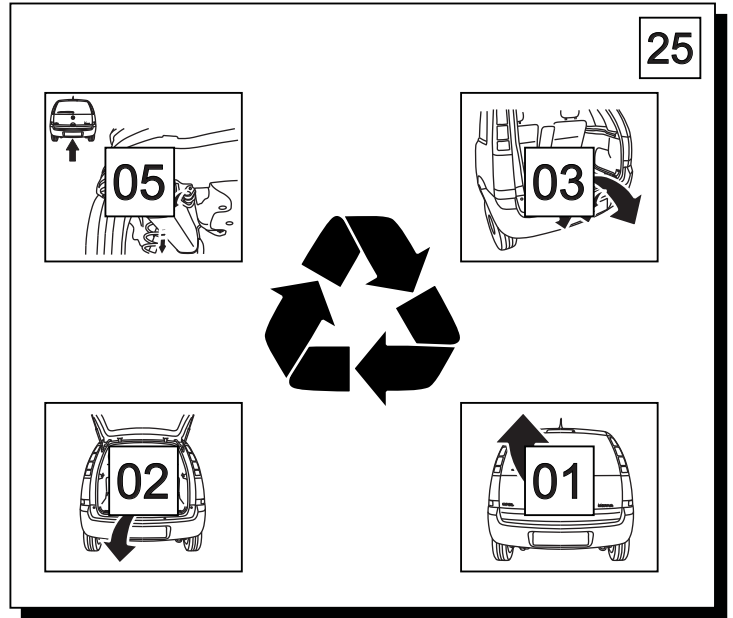

24



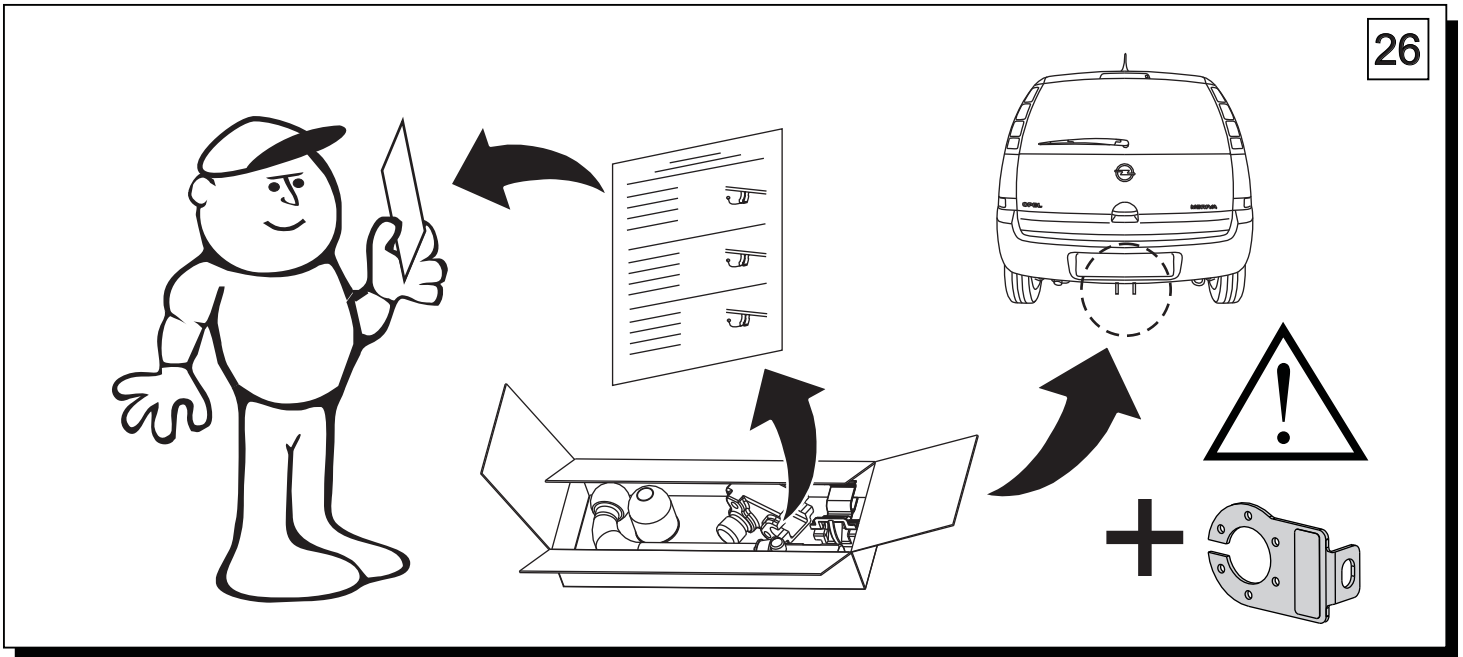

25



26

	M6 - 11 Nm	M8 - 25 Nm
	M10 - 50 Nm	M12 - 87 Nm
	M14 - 138 Nm	M16 - 210 Nm

 **0 km** →  **1000 km**