

## FITTING INSTRUCTION

Clamp mark in acc. with		Cables joining
ISO	PN	
1	L	Left directional lights
2	+	Rear fog lights
3	31	Ground
4	R	Right directional lights
5	58R	Right side parking lights
6	54	Stoptlights
7	58L	Left side parking lights

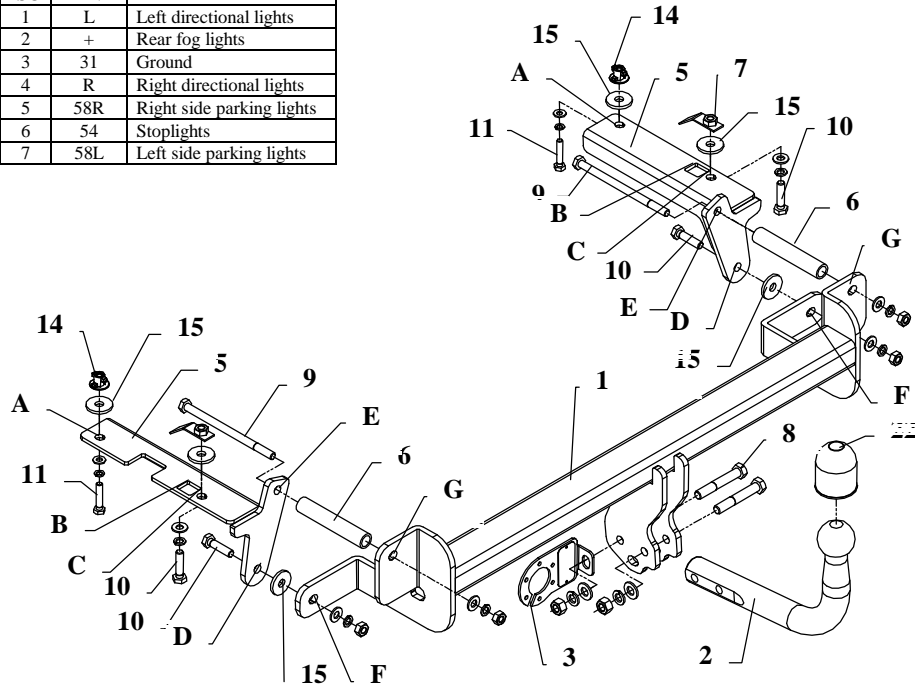

This towbar is designed to assembly in following cars:  
**OPEL ZAFIRA II**, produced since 2005, catalogue number **E48** and is prepared to tow trailers max total weight **1650 kg** and max vertical mass **75 kg**.

### *From manufacturer*

Thank you for buying our product. Their reliability has been confirmed in many tests. Reliability of towbar depends also on correct assembly and correct exploitation. For this reasons we kindly ask to read carefully this instruction and apply to hints.

*The towbar should be install in points described by a car producer.*

### The instruction of the assembly

1. Disassemble a bumper and metal cover. (Note! Metal cover will not reinstall).
2. In rear part, in original marked points drill holes using bit  $\varnothing 25\text{mm}$  (one hole per each side).

3. Underneath to chassis members put special nuts pos. 14 (see fig. 2). Next put elements pos. 4 and 5 in this way so holes A agree with special nuts in chassis members. Fix using bolts M8x40mm (pos. 11) – loosely. By rectangular holes B put to the chassis members nuts on the jib (pos. 7) in this way so nuts agree with holes C. Fix using bolts M10x40mm (pos. 10). **NOTE!!!** – between frame and elements 4 and 5 put washers  $\varnothing 25 \times 10,5 \times 4\text{mm}$  (pos. 15).
4. Through hole E put bolt M10x170mm (pos. 9). From outside on this bolt put distance bushing (pos. 6). Next put main bar of the towbar (pos. 1):
  - hole G put on bolt M10x170mm (pos. 9) and fix loosely
  - hole F fix to rear wall using bolt M10x40mm (pos. 10)**NOTE!!!** – remember to put washer (pos. 15) between frame and elements 4 and 5

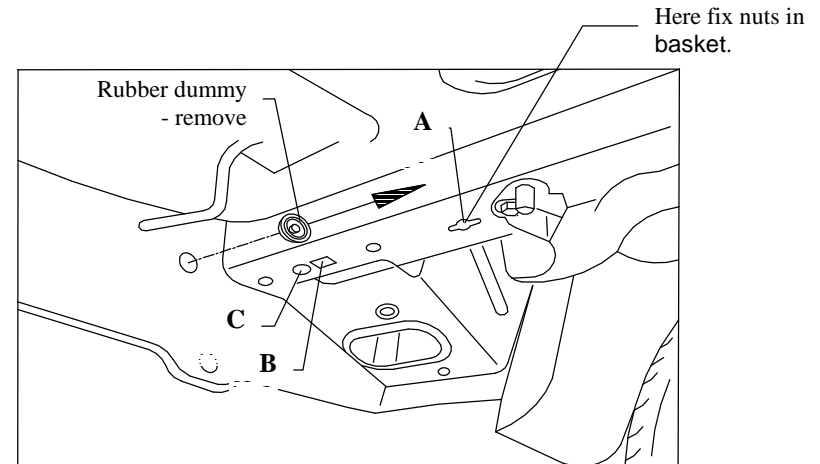

5. In bottom part of the bumper cut out fragment width 60mm and 150mm deep.
6. Reinstall all uninstalled elements.
7. Fix tow-ball (pos. 2) and socket plate (pos. 3) using bolts M12x75mm (pos. 8) from equipment.
8. Connect electric wires according to the instruction of the car. (Recommend to make at authorized service station)
9. Complete the paint coating damaged during installation.

Torque settings for nuts and bolts (8,8):

**M 8** - 25 Nm

**M 10** - 55 Nm

**M 12** - 85 Nm

**M 14** - 135 Nm











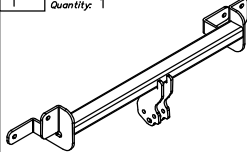





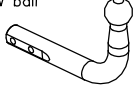



### NOTE

After install the towbar you should get adequate note in registration book (at authorised service station). The car should be equipped with:

- Indicators
- Tow mirrors

After 1000km of exploitation check all bolts and nuts. The ball of towbar must be always kept clear and conserve with a grease.

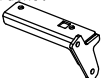
## Towbar equipment:

Pos. 1 Name: Main bar Quantity: 1	Pos. 6 Name: Distance bushing Quantity: 2	Pos. 12 Name: Nut 8 B Quantity: 2 Dim.: M12	Pos. 18 Name: Plain washer Quantity: 2 Dim.: $\phi$ 8,5 mm
			
	Pos. 7 Name: Nut on jib Quantity: 2	Pos. 13 Name: Nut 8 B Quantity: 4 Dim.: M10	Pos. 19 Name: Spring washer Quantity: 2 Dim.: $\phi$ 12,2 mm
			
Pos. 2 Name: Tow ball Quantity: 1	Pos. 8 Name: Bolt 8,8 B Quantity: 2 Dim.: M12x75mm	Pos. 14 Name: Nut specjal Quantity: 2 Dim.: M8	Pos. 20 Name: Spring washer Quantity: 6 Dim.: $\phi$ 10,2 mm
			
Pos. 3 Name: Socket plate Quantity: 1	Pos. 9 Name: Bolt 8,8 B Quantity: 2 Dim.: M10x170mm	Pos. 15 Name: Washer Quantity: 6 Dim.: $\phi$ 25x $\phi$ 10,5x4mm	Pos. 21 Name: Spring washer Quantity: 2 Dim.: $\phi$ 8,2 mm
			
Pos. 4 Name: Left bracket Quantity: 1	Pos. 10 Name: Bolt 8,8 B Quantity: 2 Dim.: M10x40mm	Pos. 16 Name: Plain washer Quantity: 2 Dim.: $\phi$ 13 mm	Pos. 22 Name: Ball cover Quantity: 1
			
Pos. 5 Name: Right bracket Quantity: 1	Pos. 11 Name: Bolt 8,8 B Quantity: 2 Dim.: M8x40mm	Pos. 17 Name: Plain washer Quantity: 6 Dim.: $\phi$ 10,5 mm	
			



## PPUH AUTO-HAK Sp.J.

Produkcja Zaczepów Kulowych  
Henryk & Zbigniew Nejman  
76-200 SŁUPSK ul. Słoneczna 16K  
tel./fax. (059) 8-414-414; 8-414-413  
E-mail: office@autohak.com.pl  
www.autohak.com.pl

## Towing hitch (without electrical set)

Class: **A50-X** Cat. no. **E48**

Designed for:

Manufacturer: **OPEL**

Model: **ZAFIRA II**

produced since 2005

Technical data:

**D-value: 9,6 kN**

maximum trailer weight: **1650 kg**

maximum vertical cup mass: **75 kg**

Approval number according to Directive 94/20/EC: **e20\*94/20\*0096\*00**

## Foreword

This towbar is designed according to rules of safety traffic regulations. The towing hitch is a safety component and can be install only by qualified personnel. Any alteration or conversion of the towing hitch is prohibited and would lead to cancellation of design certification. Remove insulating compound and underseal from vehicle (if present) in the area of the matting surfaces of the towing hitch.

The vehicle manufacturer's specifications regarding trailer load and max. vertical cup load are decisive for driving whereat values for the towing hitch cannot be exceeded.

*D-value formula:*

$$\frac{\text{Max trailer weight [kg]} \times \text{Max vehicle weight [kg]}}{\text{Max trailer weight [kg]} + \text{Max vehicle weight [kg]}} \times \frac{9,81}{1000} = D \text{ [kN]}$$