

FITTING INSTRUCTION

Clamp mark in acc. with		Cables joining
ISO	PN	
1	L	Left directional lights
2	+	Rear fog lights
3	31	Ground
4	R	Right directional lights
5	58R	Right side parking lights
6	54	Stoplights
7	58L	Left side parking lights

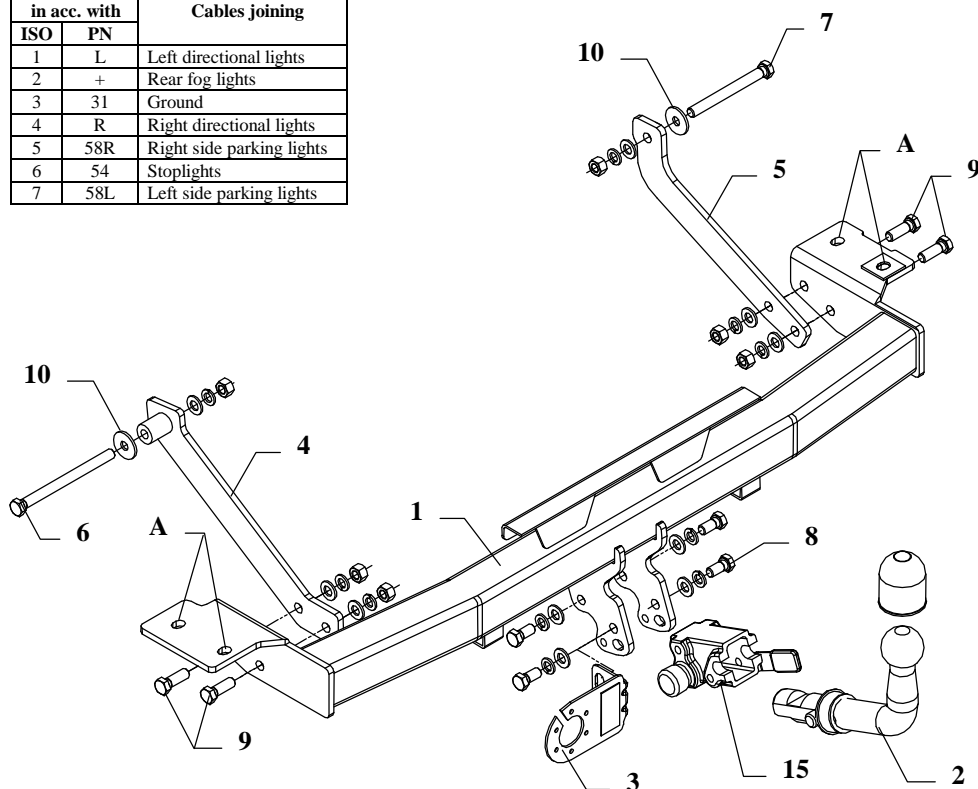

This towbar is designed to assembly in following car: **HYUNDAI H200; SATELITE/STAREX (H1) VAN**, produced since 07.1999 till 2008, catalogue no. **J15A** and is prepared to tow trailers max total weight **2000 kg** and max vertical load **80 kg**.

From manufacturer

Thank you for buying our product. Their reliability has been confirmed in many tests. Reliability of towbar depends also on correct assembly and right operation. For this reasons we kindly ask to read carefully this instruction and apply to hints.

The towbar should be install in points described by a car producer.

The instruction of the assembly

1. Disassemble the bumper and its metal filling.
2. Take out the spare wheel.
3. Apply the main bar of the towbar (pos. 1) to the frame of the car and through holes (pos. A) fix it loosely using bolts remaining after metal fulfillment disassembly.
4. Apply brackets (pos. 4 and 5) as showed on the drawing and fix them using bolts from towbar accessories.
5. Install the bumper.
6. Fix body of the automat (pos. 15) and the socket plate (pos. 3) using bolts M12x25mm (pos. 8) from accessories. Place tow-ball (pos. 2) according to supplied instruction.
7. Tighten all bolts according to the torque shown in the table.
8. Connect electric wires of 7-poles socket according to the instruction of the car. (Recommend to make at authorized service station)
9. Complete paint layer damaged during installation.

Torque settings for nuts and bolts (8,8):

M6 - 11 Nm	M8 - 25 Nm	M10 - 50 Nm
M12 - 87 Nm	M14 - 138 Nm	M16 - 210 Nm











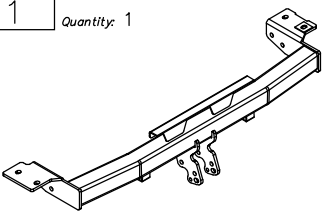
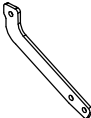

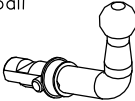
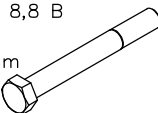
NOTE

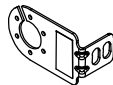
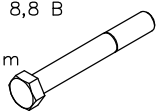
After install the towbar you should get adequate note in registration book (at authorised service station).The car should be equipped with:

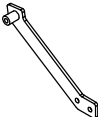
- Indicators
- Tow mirrors

After 1000km of exploitation check all bolts and nuts. The ball of towbar must be always kept clear and conserve with a grease.

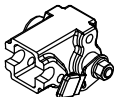
Towbar accessories:

Pos. 1	Name: Main bar Quantity: 1	Pos. 5	Name: Right arm Quantity: 1	Pos. 11	Name: Nut 8 B Quantity: 6 Dim.: M12
					
Pos. 2	Name: Tow ball Quantity: 1	Pos. 6	Name: Bolt 8,8 B Quantity: 1 Dim.: M12x150mm	Pos. 12	Name: Plain washer Quantity: 10 Dim.: Ø 13 mm
					
Pos. 3	Name: Socket plate Quantity: 1	Pos. 7	Name: Bolt 8,8 B Quantity: 1 Dim.: M12x120mm	Pos. 13	Name: Spring washer Quantity: 10 Dim.: Ø 12,2 mm
					
Pos. 4	Name: Left arm Quantity: 1	Pos. 8	Name: Bolt 8,8 B Quantity: 4 Dim.: M12x25mm	Pos. 14	Name: Ball cover Quantity: 1
					
		Pos. 9	Name: Bolt 8,8 B Quantity: 4 Dim.: M12x35mm	Pos. 15	Name: Body of the automat Quantity: 1
					
		Pos. 10	Name: Washer Quantity: 2 Dim.: Ø35xØ13x3mm	Pos. 16	Name: Body plug Quantity: 1
					



PPUH AUTO-HAK Sp.J.

Produkcja Zaczepów Kulowych
Henryk & Zbigniew Nejman
76-200 SŁUPSK ul. Słoneczna 16K
tel/fax (059) 8-414-414; 8-414-413
E-mail: office@autohak.com.pl
www.autohak.com.pl

Towing hitch (without electrical set)

Class: **A50-X** Cat. no. **J15A**

Designed for:

Manufacturer: **HYUNDAI**

Model: **H200**

Type: **SATELITE/STAREX (H1) VAN**

produced since 07.1999 till 2008

Technical data:

D-value: 12,03 kN

maximum trailer weight: **2000 kg**

maximum vertical cup load: **80 kg**

Approval number according to Directive 94/20/EC: e20*94/20*0573*00

Foreword

This towbar is designed according to rules of safety traffic regulations. The towing hitch is a safety component and can be install only by qualified personnel. Any alteration or conversion of the towing hitch is prohibited and would lead to cancellation of design certification. Remove insulating compound and underseal from vehicle (if present) in the area of the matting surfaces of the towing hitch.

The vehicle manufacturer's specifications regarding trailer load and max. vertical cup load are decisive for driving, and values for the towing hitch cannot be exceeded.

D-value formula:

$$\frac{\text{Max trailer weight [kg]} \times \text{Max vehicle weight [kg]}}{\text{Max trailer weight [kg]} + \text{Max vehicle weight [kg]}} \times \frac{9,81}{1000} = D \text{ [kN]}$$