

FITTING INSTRUCTION

Clamp mark in acc. with		Cables joining
ISO	PN	
1	L	Left directional lights
2	+	Rear fog lights
3	31	Ground
4	R	Right directional lights
5	58R	Right side parking lights
6	54	Stoptlights
7	58L	Left side parking lights

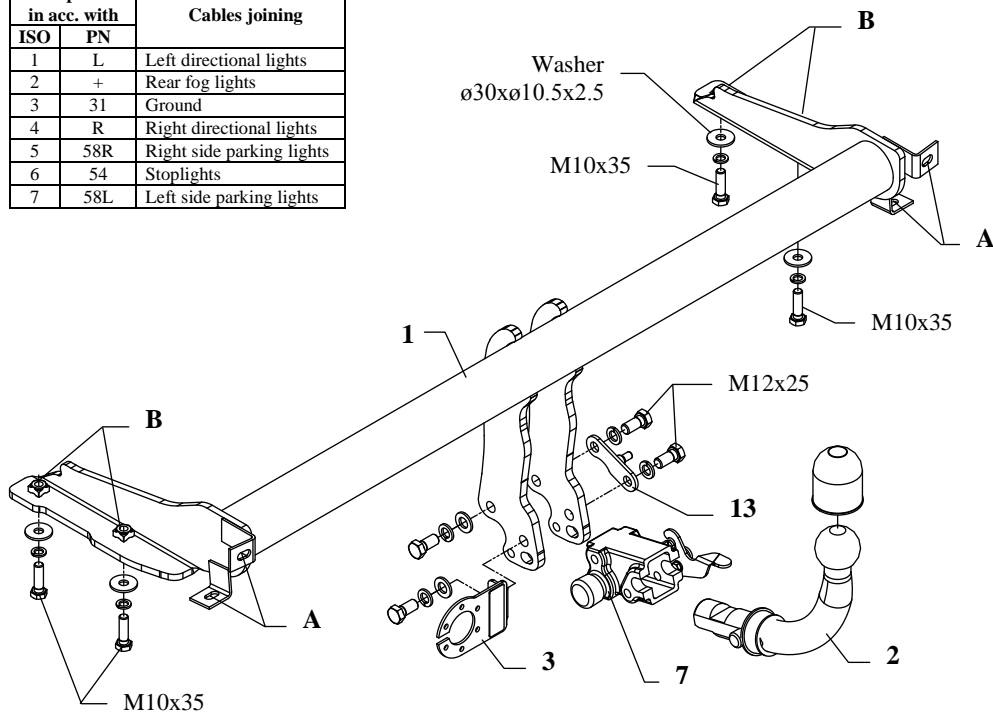

Fig. 1

This towbar is designed to assembly in following cars: **VOLKSWAGEN GOLF II, 3/5 doors, wide bumper**, produced since 08.1989 till 10.1991, catalogue no. **K32A** and is prepared to tow trailers max total weight **1500 kg** and max vertical load **75 kg**.

From manufacturer

Thank you for buying our product. Their reliability has been confirmed in many tests. Reliability of towbar depends also on correct assembly and right operation. For this reasons we kindly ask to read carefully this instruction and apply to hints.

The towbar should be install in points described by a car producer.

The instruction of the assembly

1. Disassemble the bumper by unscrewing four bolts M10 on the left and right side (from the bottom of the car).
2. Unscrew factory brackets, which fasten the bumper (not used anymore).
3. Cut out the fragment of the plastic fulfilment of the bumper, as showed on the fig. 2 and the fragment of the metal fulfilment, as showed on the fig. 3. Then fix the bumper to the towbar through holes (pos. A) in place of disassembled brackets.

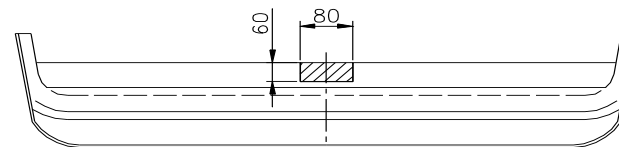

Fig. 2

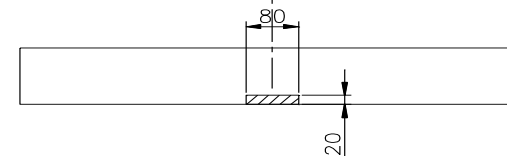

Fig. 3

4. Put so prepared „bumper with the towbar” to the car and fix through holes of the towbar (pos. B) using bolts M10x35mm (pos. 5).
5. Fix body of the automat (pos. 7) and the socket plate (pos. 3) using bolts M12x25mm (pos. 4) from accessories. Place tow-ball (pos. 2) according to supplied instruction.
6. Tighten all bolts according to the torque shown in the table.
7. Connect electric wires of 7-poles socket according to the instruction of the car. (Recommend to make at authorized service station).
8. Complete paint layer damaged during installation.

Torque settings for nuts and bolts (8,8):

M6 - 11 Nm	M8 - 25 Nm	M10 - 50 Nm
M12 - 87 Nm	M14 - 138 Nm	M16 - 210 Nm

NOTE

After install the towbar you should get adequate note in registration book (at authorised service station).The car should be equipped with:

- Indicators
- Tow mirrors

After 1000km check all bolts and nuts. The ball of towbar must be always kept clear and conserve with a grease.

Towbar accessories:

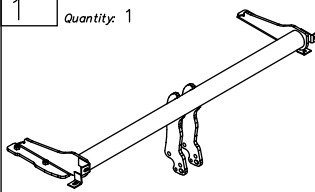
Pos. 1	Name: Main bar Quantity: 1	Pos. 5	Name: Bolt 8,8 B Quantity: 4 Dim.: M10x35mm	Pos. 10	Name: Spring washer Quantity: 4 Dim.: \varnothing 10,2 mm
		Pos. 6	Name: Washer Quantity: 4 Dim.: \varnothing 30x \varnothing 10.5x2.5mm	Pos. 11	Name: Ball cover Quantity: 1
		Pos. 7	Name: Body of the automat Quantity: 1	Pos. 12	Name: Body plug Quantity: 1
Pos. 2	Name: Tow ball Quantity: 1	Pos. 8	Name: Plain washer Quantity: 2 Dim.: \varnothing 13 mm	Pos. 13	Name: Safety fish-plate Quantity: 1
Pos. 3	Name: Socket plate Quantity: 1	Pos. 9	Name: Spring washer Quantity: 4 Dim.: \varnothing 12,2 mm		
Pos. 4	Name: Bolt 8,8 B Quantity: 4 Dim.: M12x25mm				



PPUH AUTO-HAK Sp.J.

Produkcja Zaczepów Kulowych
Henryk & Zbigniew Nejman
76-200 SŁUPSK ul. Słoneczna 16K
tel/fax (059) 8-414-414; 8-414-413
e-mail: office@autohak.com.pl
www.autohak.com.pl

Towing hitch (without electrical set)

Class: **A50-X** Cat. no. **K32A**

Designed for:

Manufacturer: **VOLKSWAGEN**

Model: **GOLF II**

Type: **3/5 doors, wide bumper**

produced since 08.1989 till 10.1991

Technical data:

D-value: 7,6 kN

maximum trailer weight: **1500 kg**

maximum vertical cup load: **75 kg**

Approval number according to Directive 94/20/EC: **e20*94/20*1347*01**

Foreword

This towbar is designed according to rules of safety traffic regulations. The towing hitch is a safety component and can be install only by qualified personnel. Any alteration or conversion of the towing hitch is prohibited and would lead to cancellation of design certification. Remove insulating compound and underseal from vehicle (if present) in the area of the matting surfaces of the towing hitch.

The vehicle manufacturer's specifications regarding trailer load and max. vertical cup load are decisive for driving whereat values for the towing hitch cannot be exceeded.

D-value formula:

$$\frac{\text{Max trailer weight [kg]} \times \text{Max vehicle weight [kg]}}{\text{Max trailer weight [kg]} + \text{Max vehicle weight [kg]}} \times \frac{9,81}{1000} = D \text{ [kN]}$$