

## FITTING INSTRUCTION

Clamp mark in acc. with		Cables joining
ISO	PN	
1	L	Left directional lights
2	+	Rear fog lights
3	31	Ground
4	R	Right directional lights
5	58R	Right side parking lights
6	54	Stoplights
7	58L	Left side parking lights

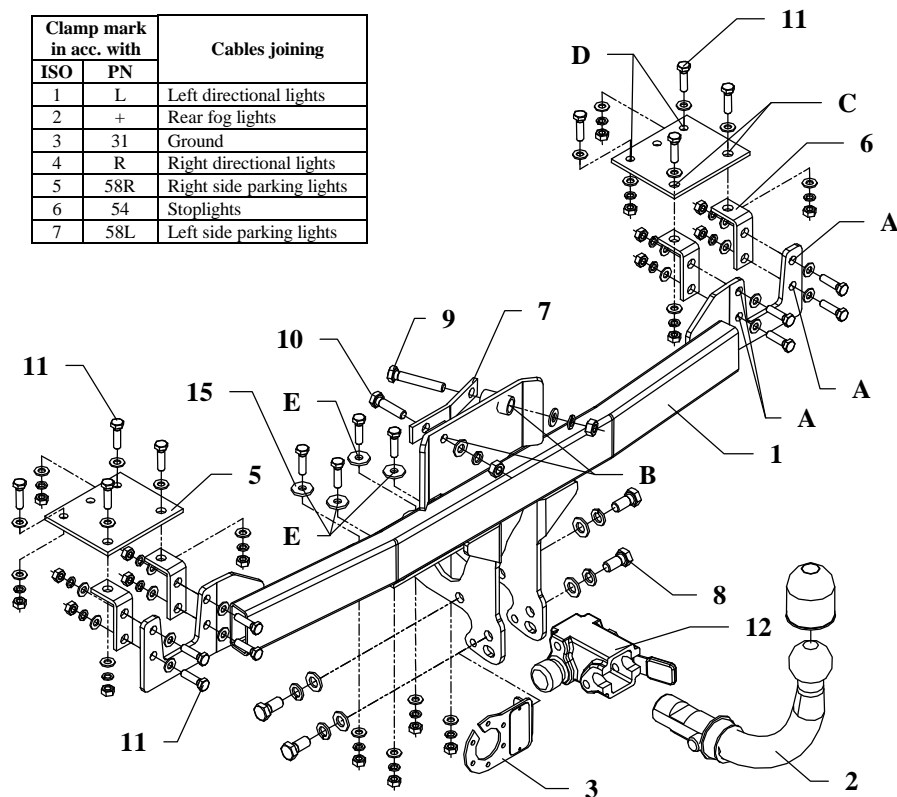

This towing hitch is designed to assembly in following cars:  
**FIAT BRAVO, 3 doors**, produced since 1995 till 2001, catalogue no. **R10A** and is prepared to tow trailers max total weight **1400 kg** and max vertical load **75 kg**.

### *From manufacturer*

Thank you for buying our product. Their reliability has been confirmed in many tests. Reliability of towing hitch depends also on correct assembly and right operation. For this reasons we kindly ask to read carefully this instruction and apply to hints.

*The towing hitch should be installed in points described by a car producer.*

## The instruction of the assembly

1. Take out a spare wheel. Disassemble a bumper and remove his filling.
2. Inside trunk disassemble cover plates of sides and rear wall and take out felt-mat from spare wheel housing.
3. On the left and right side of rear wall twist off plugs off chassis members and remove rest of rivet.
4. Put main bar of the towing hitch (pos. 1) to rear wall (in axis) and then through holes (pos. A) drill holes using bit  $\varnothing 9\text{mm}$ .
5. Underneath a car put angle elements (pos. 6) and through holes (pos. A) fix with main bar using bolts M8x30mm (pos. 11).
6. Through holes (pos. B) drill using bit  $\varnothing 11\text{mm}$  and next fix using bolt M10x40mm and bolt M10x60mm using angle fish-plate (pos. 7).
7. Underneath a car drill holes through points pos. C inside the trunk, use bit  $\varnothing 9\text{mm}$ .
8. Inside trunk put fish-plates (pos. 5) and through holes pos. C fix it by bolts M8x30mm (pos. 11).
9. Through holes pos. D of fish-plates make holes  $\varnothing 9\text{mm}$  and fix by bolts M8x30mm (pos. 11) and washers.
10. Underneath a car through holes pos. E drill using bit  $\varnothing 9\text{mm}$  and fix by bolts M8x30mm (pos. 11).
11. Cut out the bumper according to supplied template, then reassemble it to a car.
12. Fix body of the automat (pos. 12) and the socket plate (pos. 3) using bolts M12x25mm (pos. 8) from equipment. Place tow-ball (pos. 2) according to supplied instruction.
13. Fix tight all bolts according to the torque shown in the table.
14. Connect electric wires of 7-poles socket according to the instruction of the car. (Recommend to make at authorized service station).
15. Complete paint layer damaged during installation.

Torque settings for nuts and bolts (8,8):

<b>M 8</b> - 25 Nm	<b>M 10</b> - 55 Nm
<b>M 12</b> - 85 Nm	<b>M 14</b> - 135 Nm











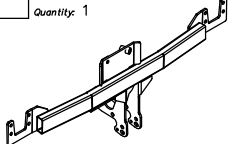



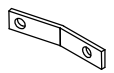

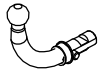

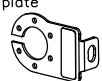

### NOTE

After install the towing hitch you should get adequate note in registration book (at authorised service station).The car should be equipped with:

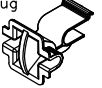
- Indicators
- Tow mirrors

After 1000km check all bolts and nuts. The ball of towing hitch must be always kept clear and conserve with a grease.

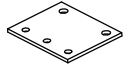
## Towing hitch equipment:

Pos. 1 Name: Main bar Quantity: 1 	Pos. 6 Name: Angle bar Quantity: 4 	Pos. 12 Name: Body of the automat Quantity: 1 	Pos. 18 Name: Plain washer Quantity: 36 Dim.: Ø 8,5 mm 
	Pos. 7 Name: Angle fish-plate Quantity: 1 	Pos. 13 Name: Nut 8 B Quantity: 2 Dim.: M10 	Pos. 19 Name: Spring washer Quantity: 4 Dim.: Ø 12,2 mm 
Pos. 2 Name: Tow ball Quantity: 1 	Pos. 8 Name: Bolt 8,8 B Quantity: 4 Dim.: M12x25mm 	Pos. 14 Name: Nut 8 B Quantity: 20 Dim.: M8 	Pos. 20 Name: Spring washer Quantity: 2 Dim.: Ø 10,2 mm 
Pos. 3 Name: Socket plate Quantity: 1 	Pos. 9 Name: Bolt 8,8 B Quantity: 1 Dim.: M10x60mm 	Pos. 15 Name: Washer Quantity: 4 Dim.: Ø25xØ9x3mm 	Pos. 21 Name: Spring washer Quantity: 20 Dim.: Ø 8,2 mm 
Pos. 4 Name: Body plug Quantity: 1 	Pos. 10 Name: Bolt 8,8 B Quantity: 1 Dim.: M10x40mm 	Pos. 16 Name: Plain washer Quantity: 4 Dim.: Ø 13 mm 	Pos. 22 Name: Ball cover Quantity: 1 
Pos. 5 Name: Fish-plate Quantity: 2 	Pos. 11 Name: Bolt 8,8 B Quantity: 20 Dim.: M8x30mm 	Pos. 17 Name: Plain washer Quantity: 2 Dim.: Ø 10,5 mm 	



## PPUH AUTO-HAK S.J.

Produkcja Haków Holowniczych  
Henryk & Zbigniew Nejman  
76-200 SŁUPSK ul. Słoneczna 16K  
tel/fax (059) 8-414-414; 8-414-413  
E-mail: [office@autohak.com.pl](mailto:office@autohak.com.pl)  
[www.autohak.com.pl](http://www.autohak.com.pl)

## Towing hitch (without electrical set)

Class: **A50-X** Cat. no. **R10A**

Designed for:

Manufacturer: **FIAT**

Model: **BRAVO**

Type: **3 doors**

produced since 1995 till 2001

Technical data:

**D-value: 7,9 kN**

maximum trailer weight: **1400 kg**

maximum vertical cup load: **75 kg**

Approval number according to Directive 94/20/EC: **e20\*94/20\*0311\*00**

## Foreword

This towing hitch is designed according to rules of safety traffic regulations. The towing hitch is a safety component and can be install only by qualified personnel. Any alteration or conversion of the towing hitch is prohibited and would lead to cancellation of design certification. Remove insulating compound and underseal from vehicle (if present) in the area of the matting surfaces of the towing hitch. The vehicle manufacturer's specifications regarding trailer load and max. vertical cup load are decisive for driving whereat values for the towing hitch cannot be exceeded.

*D-value formula:*

$$\frac{\text{Max trailer weight [kg]} \times \text{Max vehicle weight [kg]}}{\text{Max trailer weight [kg]} + \text{Max vehicle weight [kg]}} \times \frac{9,81}{1000} = D \text{ [kN]}$$