

FITTING INSTRUCTIONS

Clamp mark in acc. with		Cables joining
ISO	PN	
1	L	Left directional lights
2	+	Rear fog lights
3	31	Ground
4	R	Right directional lights
5	58R	Right side parking lights
6	54	Stoplights
7	58L	Left side parking lights

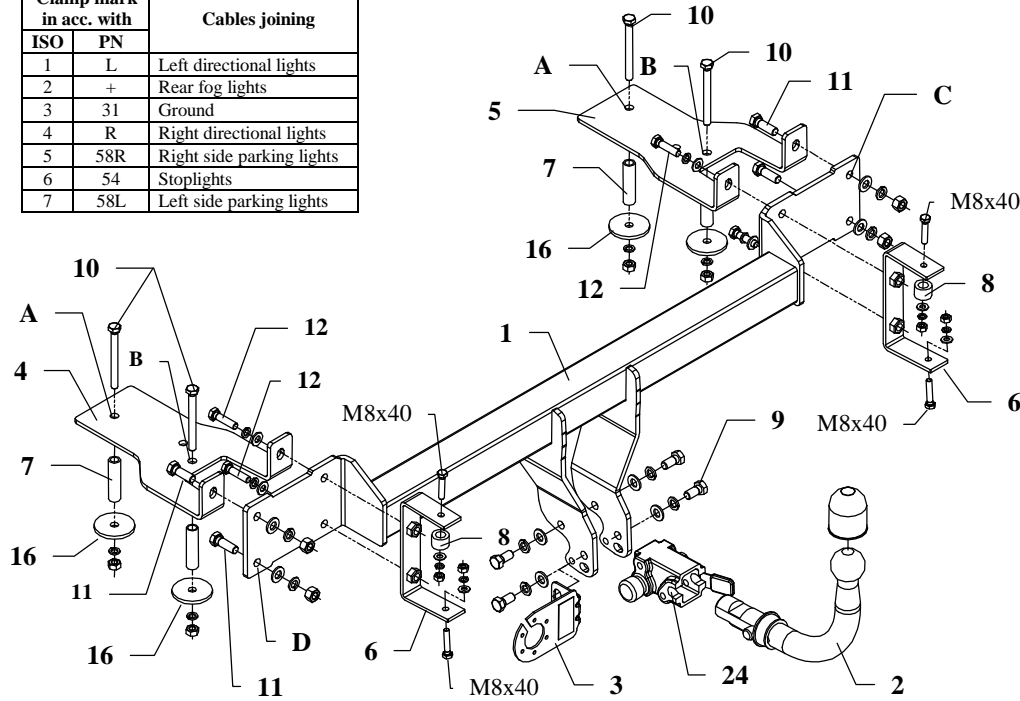

This towbar is designed to assembly in following car:

KIA CLARUS 4 door, produced since 1996 till 01.1999, cat. no. **T07A** and is prepared to tow trailers max total weight **1650 kg** and max vertical load **75 kg**.

From manufacturer

Thank you for buying our product. Their reliability has been confirmed in many tests. Reliability of towbar depends also on correct assembly and right operation. For this reasons we kindly ask to read carefully this instruction and apply to hints.

The towbar should be install in points described by a car producer.

Fitting instructions

1. Disassemble the bumper.
2. Remove carpet from the boot.

Fig.1

Larger distance

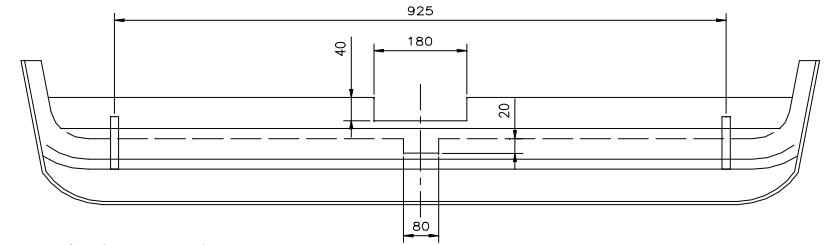
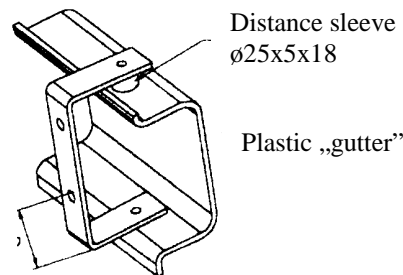

Fig. 2. Bumper's cut out

3. Put elements (pos. 4 and 5) to the trunk as shown in the fig. A. Hole (pos. A) put on existing hole next through hole pos. B mark points and drill it straight through.
 - Put away both fish plates (4 and 5) and next drill holes using bit $\phi 17\text{mm}$ – only in boot floor.
4. On that prepared holes put distance sleeves $L=68\text{ mm}$ (pos. 7).
 - Put fish plates (pos. 4 and 5), screw using bolts $M10 \times 100\text{mm}$ (pos. 10), loosely, as shown in the drawing.
5. Main bar of the towbar (pos. 1) put to rear part of car and screw through holes (pos. C) using bolts $M12 \times 35\text{mm}$ (pos. 11).
 - Through hole (pos. D) drill $\phi 13\text{mm}$ and next screw using bolts $M12 \times 35\text{mm}$ (pos. 11).
6. Install bumper after unscrew original handles of plastic „gutter” (not used any more). In places of unscrewed handles screw handles from towbar accessories (pos. 6) use distance sleeves (pos. 8) as shown in the fig. 1.
 - In plastic „gutter” (in axis) cut out his fragment 180×40 , and next in bottom part of bumper cut out fragment 80×20 , as shown in fig. 2.
7. Fix body of the automat (pos. 24) and the socket plate (pos. 3) using bolts $M12 \times 25\text{mm}$ (pos. 4) from accessories. Place tow-ball (pos. 2) according to supplied instruction.
8. Connect electric wires of 7-poles socket according to the instruction of the car. (Recommend to make at authorized service station).
9. Complete the paint coating damaged during installation.

Torque settings for nuts and bolts (8,8):

M 8 - 25 Nm

M 10 - 55 Nm

M 12 - 85 Nm

M 14 - 135 Nm









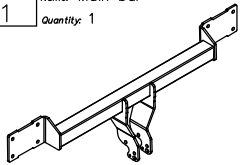
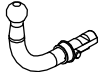

NOTE

After install the towbar you should get adequate note in registration book (at authorised service station).The car should be equipped with:

- Indicators
- Tow mirrors

After 1000km check all bolts and nuts. The ball of towbar must be always kept clear and conserve with a grease.

Towbar accessories:

Pos. 1 Name: Main bar Quantity: 1	Pos. 6 Name: Handle Quantity: 2	Pos. 12 Name: Bolt 8,8 B Quantity: 4 Dim.: M10x40mm	Pos. 19 Name: Plain washer Quantity: 4 Dim.: \varnothing 8,5 mm
	Pos. 7 Name: Distance sleeve I Quantity: 4 Dim.: \varnothing 17,2x2,35mm L=58mm	Pos. 13 Name: Nut 8 B Quantity: 4 Dim.: M12	Pos. 20 Name: Spring washer Quantity: 8 Dim.: \varnothing 12,2 mm
Pos. 2 Name: Tow ball Quantity: 1	Pos. 8 Name: Distance sleeve II Quantity: 2 Dim.: \varnothing 25x5mm L=18mm	Pos. 14 Name: Nut 8 B Quantity: 4 Dim.: M10	Pos. 21 Name: Spring washer Quantity: 8 Dim.: \varnothing 10,2 mm
	Pos. 9 Name: Bolt 8,8 B Quantity: 4 Dim.: M12x25mm	Pos. 15 Name: Nut 8 B Quantity: 4 Dim.: M8	Pos. 22 Name: Spring washer Quantity: 4 Dim.: \varnothing 8,2 mm
Pos. 3 Name: Socket plate Quantity: 1		Pos. 16 Name: Washer Quantity: 4 Dim.: \varnothing 58x \varnothing 12x5mm	Pos. 23 Name: Ball cover Quantity: 1
Pos. 4 Name: Left bracket Quantity: 1	Pos. 10 Name: Bolt 8,8 B Quantity: 4 Dim.: M10x100mm		
	Pos. 11 Name: Bolt 8,8 B Quantity: 4 Dim.: M12x35mm	Pos. 17 Name: Plain washer Quantity: 8 Dim.: \varnothing 13 mm	Pos. 24 Name: Body of the automat Quantity: 1
Pos. 5 Name: Right bracket Quantity: 1			
	Pos. 18 Name: Plain washer Quantity: 4 Dim.: \varnothing 10,5 mm		Pos. 25 Name: Body plug Quantity: 1
			



PPUH AUTO-HAK S.J.

Produkcja Zaczepów Kulowych
Henryk & Zbigniew Nejman
76-200 SŁUPSK ul. Słoneczna 16K
tel/fax (059) 8-414-414; 8-414-413
Email: office@autohak.com.pl
www.autohak.com.pl

Towing hitch (without electrical set)

Class: **A50-X** Cat. no. **T07A**

Designed for:

Manufacturer: **KIA**

Model: **CLARUS**

Type: **4 door**

produced since 1996 till 01.1999

Technical data:

D-value: 8,4 kN

maximum trailer weight: **1650 kg**

maximum vertical cup load: **75 kg**

Approval number according to Directive 94/20/EC: **e20*94/20*0614*00**

Foreword

This towbar is designed according to rules of safety traffic regulations. The towing hitch is a safety component and can be install only by qualified personnel. Any alteration or conversion of the towing hitch is prohibited and would lead to cancellation of design certification. Remove insulating compound and underseal from vehicle (if present) in the area of the matting surfaces of the towing hitch.

The vehicle manufacturer's specifications regarding trailer load and max. vertical cup load are decisive for driving, and values for the towing hitch cannot be exceeded.

D-value formula:

$$\frac{\text{Max trailer weight [kg]} \times \text{Max vehicle weight [kg]}}{\text{Max trailer weight [kg]} + \text{Max vehicle weight [kg]}} \times \frac{9,81}{1000} = D \text{ [kN]}$$