

## FITTING INSTRUCTION

Clamp mark in acc. with		Cables joining
ISO	PN	
1	L	Left directional lights
2	+	Rear fog lights
3	31	Ground
4	R	Right directional lights
5	58R	Right side parking lights
6	54	Stoplights
7	58L	Left side parking lights

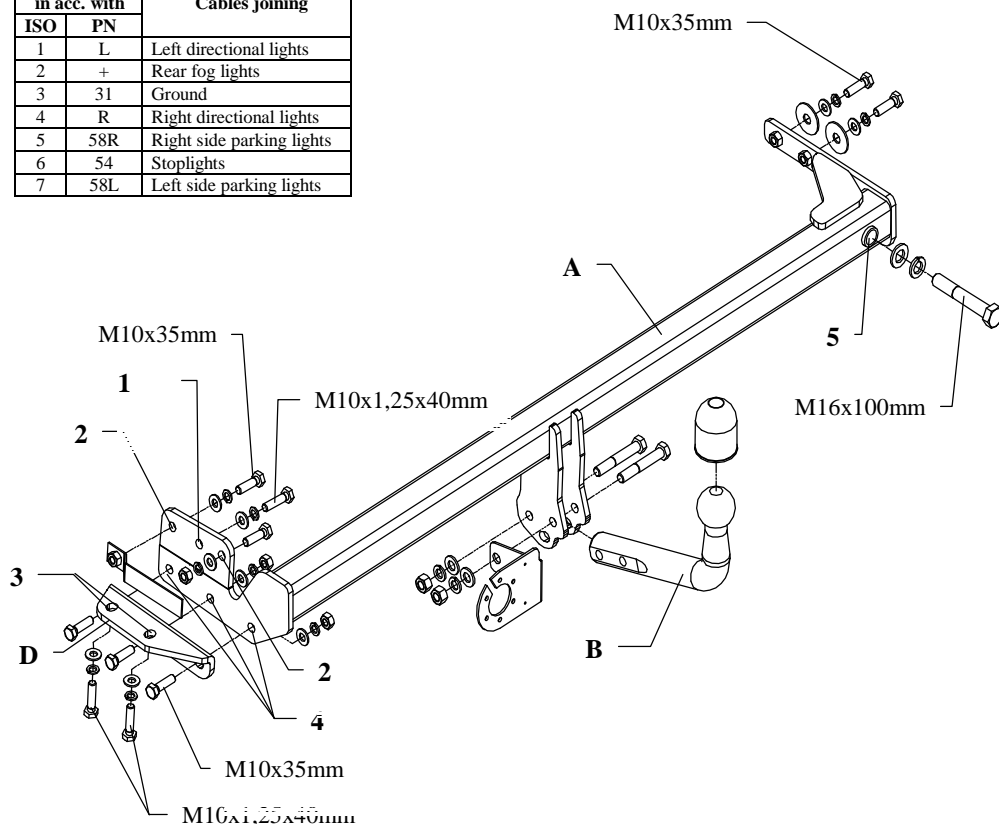

This towbar can be used in following car:  
**NISSAN PREMERA P11 4/5 door**, produced from 09.1999 to 02.2002,  
 catalogue no. **V55** and is prepared to tow trailers max total weight **1700 kg**  
 and max vertical load **75 kg**.

### Foreword

Thank you for buying our product. This towbar is design according to rules of safety traffic regulations and their reliability has been confirmed in many tests. Reliability of towbar also depends on correct assembly and correct exploitation. For this reasons we kindly ask to read carefully this instruction and apply to hints.

*The towbar should be install in places described by a car producer.*

## Fitting instructions

1. Disassemble the bumper.
2. Unscrew rear handle of the muffler.
3. Slide the towbar's bar handle to the right chassis member and fix it as it show the drawing
4. Fix the left handle with the inside side of the chassis member through the holes (pos. 1) using M 10 x 1,25 x 40, then fix the element (pos. D) with the chassis member through the holes (pos. 3) using M 10 x 1,25 x 40 and with the towbar through the holes (pos.4) using M 10 x 35
5. Screw bolt M16 x 100 mm through hole pos. 5 M16 x 100 mm.
6. Assemble the muffler handle.
7. Cut out fragment of the bumper (50 mm width and 110 mm length) and screw it..
8. Screw tow-ball (pos. B) and socket plate using bolts M12x75mm from equipment.
9. Screw all bolts according to the torque shown in the table.
10. Connect electric wires according to the instruction of the car. (Recommend to make at authorized service station)
11. Complete the paint cover of towbar (during the mounting paint cover could be destroyed)

Torque settings for nuts and bolts (8,8):

<b>M 8</b>	25 Nm	<b>M 10</b>	55 Nm
<b>M 12</b>	85 Nm	<b>M 14</b>	135 Nm

### NOTE

After install the towbar you should get adequate note in registration book (at authorised service station). The car should be equipped with:

- Indicators
- Tow mirrors

After 1000km check all bolts and nuts. The ball of towbar must be always kept clear and conserve with a grease.



**PPUH AUTO-HAK S.J.**

Produkcja Zaczepów Kulowych  
Henryk & Zbigniew Nejman  
76-200 SŁUPSK ul. Słoneczna 16K  
tel/fax (059) 8-414-414; 8-414-413  
E-mail: [office@autohak.com.pl](mailto:office@autohak.com.pl)  
[www.autohak.com.pl](http://www.autohak.com.pl)

---

## **Towing hitch (without electrical set)**

Class: **A50-X** Cat. no. **V55**

Designed for:

Manufacturer: **NISSAN**

Model: **PRIMERA**

Type: **4/5 doors (P11)**

produced since 09.1999 till 02.2002

Technical data:

**D-value: 8,6 kN**

maximum trailer weight: **1700 kg**

maximum vertical cup mass: **75 kg**

**Approval number acc. to regulations EKG/ONZ 55.01: E20-55R-01 1031**

### ***Foreword***

This towing hitch is designed according to rules of safety traffic regulations. The towing hitch is a safety component and can be install only by qualified personnel. Any alteration or conversion of the towing hitch is prohibited and would lead to cancellation of design certification. Remove insulating compound and underseal from vehicle (if present) in the area of the matting surfaces of the towing hitch.

The vehicle manufacturer's specifications regarding trailer mass and max. vertical cup mass are decisive for driving whereat values for the towing hitch cannot be exceeded.

*D-value formula:*

$$\frac{\text{Max trailer weight [kg]} \times \text{Max vehicle weight [kg]}}{\text{Max trailer weight [kg]} + \text{Max vehicle weight [kg]}} \times \frac{9,81}{1000} = D \text{ [kN]}$$