

FITTING INSTRUCTION

Clamp mark in acc. with		Cables joining
ISO	PN	
1	L	Left directional lights
2	+	Rear fog lights
3	31	Ground
4	R	Right directional lights
5	58R	Right side parking lights
6	54	Stoplights
7	58L	Left side parking lights

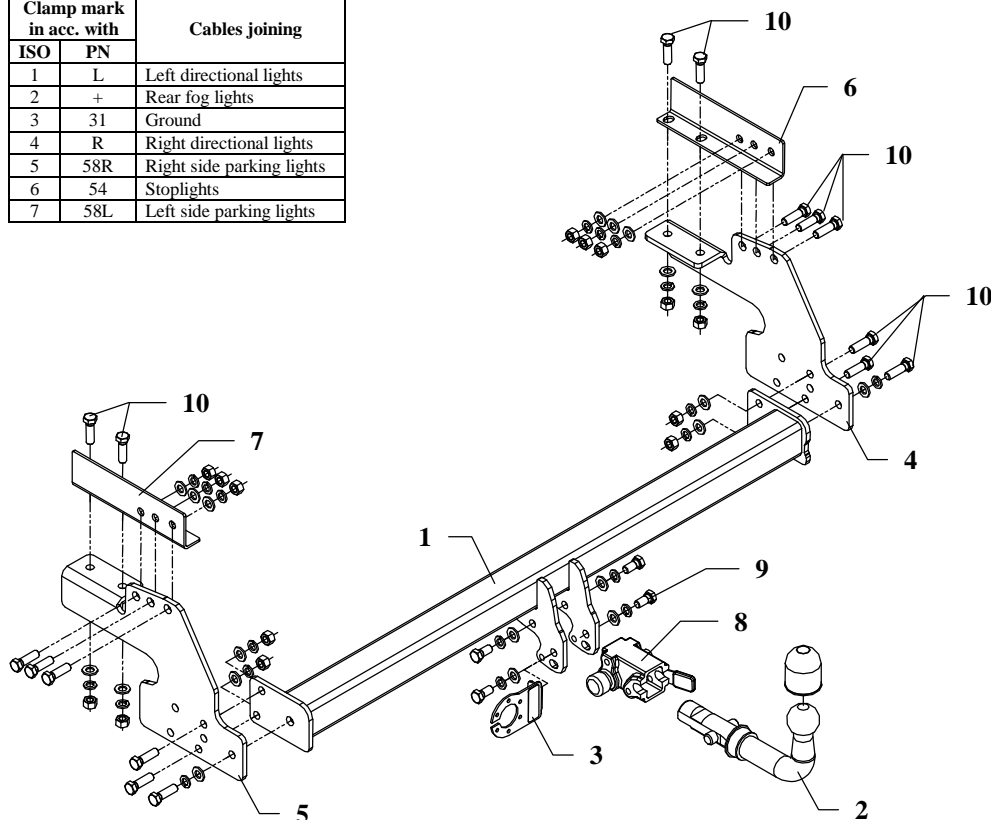

This towing hitch is designed to assembly in following cars: **NISSAN PICK-UP (pipe bumper)**, produced since 2002 and **NISSAN NP 300 PICK-UP (pipe bumper)**, produced since 2008, catalogue no. **V68A** and is prepared to tow trailers max total weight **3000 kg** and max vertical mass **100 kg**.

From manufacturer

Thank you for buying our product. Their reliability has been confirmed in many tests. Reliability of towing hitch depends also on correct assembly and right operation. For this reasons we kindly ask to read carefully this instruction and apply to hints.

The towing hitch should be install in points described by a car producer.

The instruction of the assembly

1. Dismount fixing bolts from the bumper.
2. Place side brackets between the brackets of the bumper and the chassis. Drill holes $\varnothing 13\text{mm}$ in the frame of the car (through holes of the brackets).
3. Apply brackets (pos. 4 and 5) with angle handles (pos. 6 and 7) and fix using bolts M12x40mm (pos. 10) from the towing hitch accessories.
4. Apply the main bar of the towing hitch (pos. 1) to brackets (pos. 4 and 5) and fix using bolts M12x40mm (pos. 10). At the two brackets are two sets of holes. Use one or another depending on the vehicle (4x2 or 4x4).
5. Fix body of the automat (pos. 8) and the socket plate (pos. 3) using bolts M12x25mm (pos. 9) from accessories. Place tow-ball (pos. 2) according to supplied instruction.
6. Tighten all bolts according to the torque shown in the table.
7. Connect electric wires of 7-poles socket according to the instruction of the car. (Recommend to make at authorized service station).
8. Complete paint layer damaged during installation.

Torque settings for nuts and bolts (8,8):	
M 8 - 25 Nm	M 10 - 55 Nm
M 12 - 85 Nm	M 14 - 135 Nm

NOTE

After install the towing hitch you should get adequate note in registration book (at authorised service station). The car should be equipped with:

- Indicators
- Tow mirrors

After 1000km of exploitation check all bolts and nuts. The ball of towing hitch must be always kept clear and conserve with a grease.

Towing hitch accessories:

Pos. 1 Main bar PCS.: 1	Pos. 5 Left bracket PCS.: 1	Pos. 10 Bolt 8,8 B M12x40mm PCS.: 16
	Pos. 6 Right handle PCS.: 1	Pos. 11 Nut 8 B M12 PCS.: 14
Pos. 2 Tow ball PCS.: 1	Pos. 7 Left handle PCS.: 1	Pos. 12 Plain washer Ø13mm PCS.: 20
Pos. 3 Socket plate PCS.: 1	Pos. 8 Body of the automat PCS.: 1	Pos. 13 Spring washer Ø12.2mm PCS.: 20
Pos. 4 Right bracket PCS.: 1	Pos. 9 Bolt 8,8 B M12x25mm PCS.: 4	Pos. 14 Ball cover PCS.: 1
		Pos. 15 Body plug PCS.: 1



PPUH AUTO-HAK S.J.

Produkcja Zaczepów Kulowych
Henryk & Zbigniew Nejman
76-200 SŁUPSK ul. Słoneczna 16K
tel/fax (059) 8-414-414; 8-414-413
E-mail: office@autohak.com.pl
www.autohak.com.pl

Towing hitch (without electrical set)

Class: **A50-X** Cat. no. **V68A**

Designed for:

Manufacturer: **NISSAN**

Model: **PICK-UP**

(pipe bumper),

produced since 2002 and

Manufacturer: **NISSAN**

Model: **NP 300 PICK-UP**

(pipe bumper),

produced since 2008

Technical data:

D-value: 15,0 kN

maximum trailer weight: **3000 kg**

maximum vertical cup mass: **100 kg**

Approval number according to Directive 94/20/EC: **e20*94/20*0697*00**

Foreword

This towing hitch is designed according to rules of safety traffic regulations. The towing hitch is a safety component and can be install only by qualified personnel. Any alteration or conversion of the towing hitch is prohibited and would lead to cancellation of design certification. Remove insulating compound and underseal from vehicle (if present) in the area of the matting surfaces of the towing hitch. The vehicle manufacturer's specifications regarding trailer mass and max. vertical cup mass are decisive for driving whereat values for the towing hitch cannot be exceeded.

D-value formula:

$$\frac{\text{Max trailer weight [kg]} \times \text{Max vehicle weight [kg]}}{\text{Max trailer weight [kg]} + \text{Max vehicle weight [kg]}} \times \frac{9,81}{1000} = D \text{ [kN]}$$